

GUIDELINES FOR THE DESIGN FIXING & BRACING OF Posi-STRUT FLOOR & ROOF TRUSS SYSTEMS

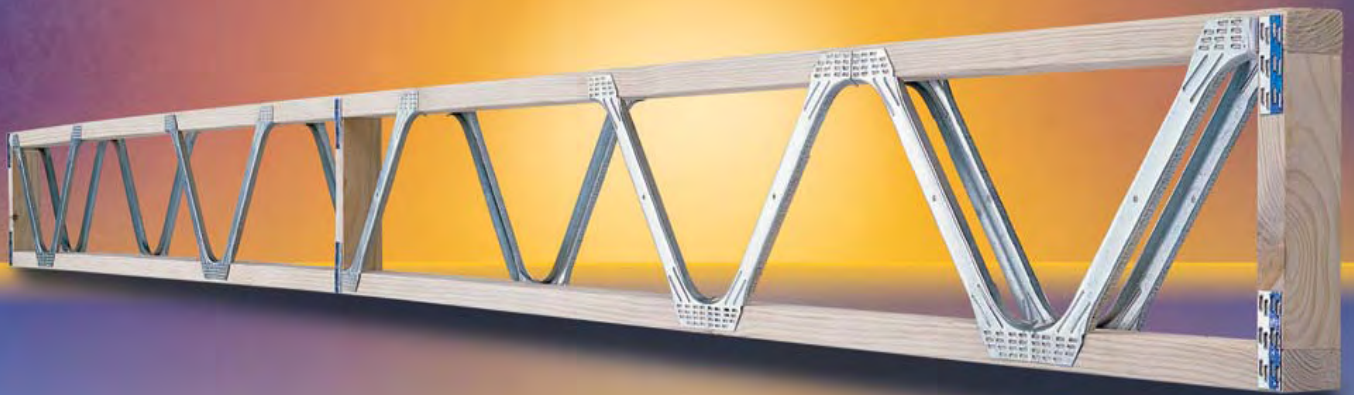

JANUARY 2007



creating the **advantage**

To find out more about MiTek's products & systems, call your local state office or visit our web site: www.mitek.com.au
VIC (03) 8795 8888 NSW (02) 8525 8000 QLD (07) 3268 1666 SA (08) 8234 1326 WA (08) 9411 2845 NZ (09) 274 7109 MALAYSIA (603) 3176 7473

HOME OF GANG-NAIL BUILDING SYSTEMS

TABLE OF CONTENTS

Posi-STRUT® Floor Truss System

Introduction	3
Advantages	3
Definitions	3
Floor Stiffness	3
Floor Loading	3
Span Charts for Bottom Chord Support	4
Span Charts for Top Chord Support	4
Supporting Structure	5
Handling and Storage	5
Set Out and Placement	6
Trimming On Site	6
Supporting External Walls	6
Supported Non-Load Bearing Walls	8
Support Details	9
Fixing and Connections	10
Strongbacks	12
Stair Openings	14
Cantilevers	16
Bracing	18
Mechanical Services	19
Posi-STRUT® Roof Rafter & Purlin System	
Introduction	20
Definition	20
Roof Loading/Camber	20
Set Out	20
Sizes	20
Hold Down Details	20
Bracing	21
Span Charts	22
Speedbrace Fixing	25

Posi-TRUSS

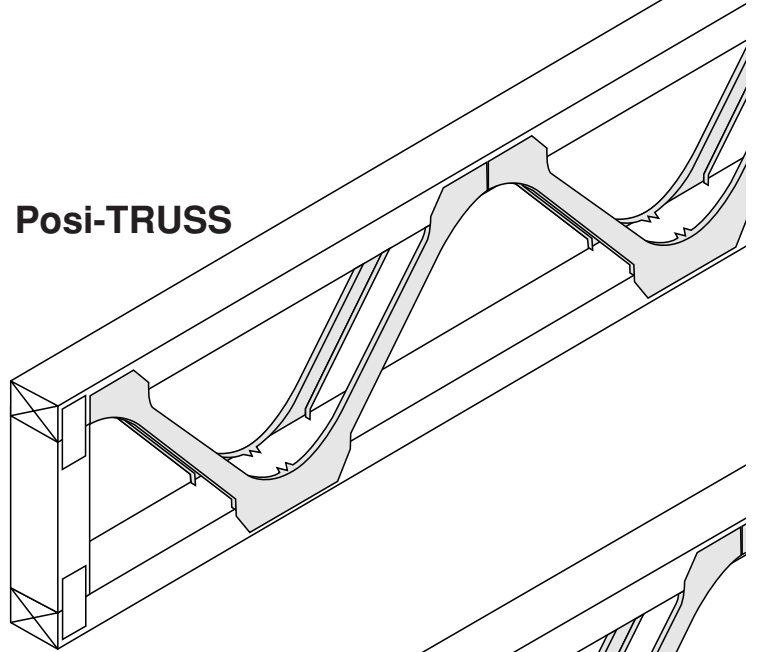

Posi-JOIST

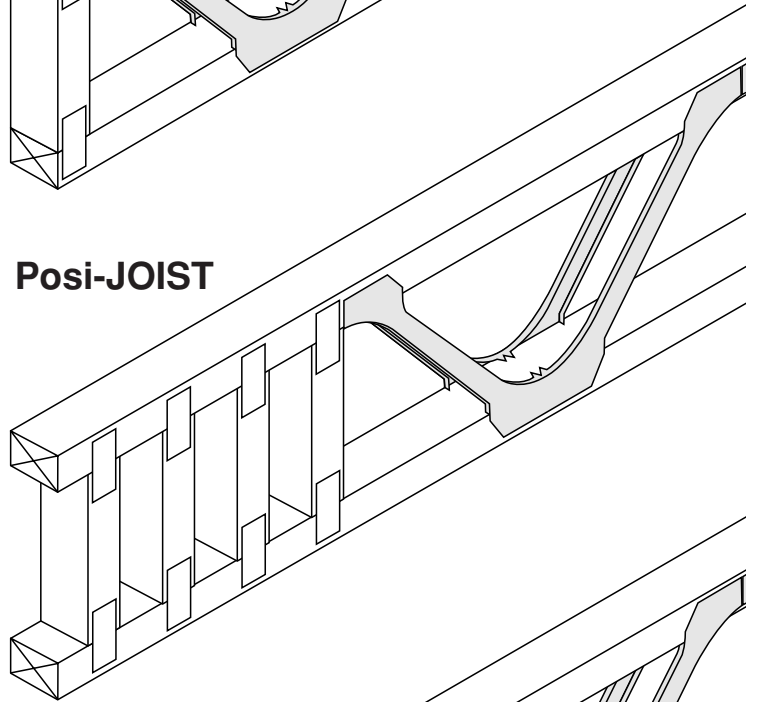

Posi-PLUS

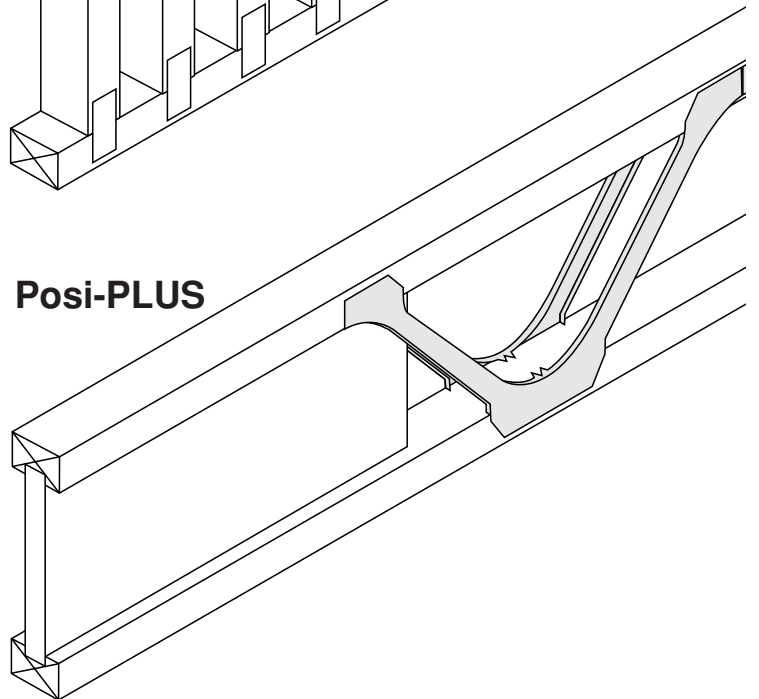

Posi-STRUT® Floor System

INTRODUCTION

Posi-STRUT® range of products are parallel chord trusses using timber chords “on flat” and the unique Posi-STRUT® metal webs.

Posi-TRUSS is a made to order parallel chorded truss commonly used as long span floor joists. They provide an economical and high quality floor structure which is easily assembled and provides excellent access for plumbing, electrical services and air conditioning ducts. Posi-TRUSS may also be used for long span rafters or purlins to carry tile or steel deck roofing.

As Posi-TRUSSES are designed and manufactured to order for specific projects, they can incorporate internal beams and special support conditions.

Posi-JOIST® and Posi-PLUS® trusses incorporate special trimmable ends and are available ex stock. Posi-JOIST® and Posi-PLUS® are designed specifically for use as floor joists in domestic type structures and should not be used for other applications without advice from a qualified engineer.

The Posi-STRUT® range of products are available in nominal 200, 250, 300 and 400mm depth. Actual overall truss depth depends on timber sizes used for the chords, and is provided in the design tables enclosed. Posi-STRUTS® make more efficient use of timber than conventional joists, as they have timber concentrated at the top and bottom of the truss where it works most efficiently. This concept is similar to that of steel universal beams, where the majority of steel is located in the flanges. The efficient use of timber, combined with the strength of the Posi-STRUT® webs, make the Posi-STRUT® range of products very lightweight, yet strong structural members.

ADVANTAGES

Posi-STRUTS® offer the following advantages over solid joists:

- Plumbing, electrical conduit and other services can be run between chords and webs.
- No drilling or notching required to accommodate services.
- Additional width available for fixing flooring.
- Ceiling material can be fixed directly to the truss bottom chords.
- Larger clear spans.
- Internal load bearing walls, piers or stumps and bearers can be reduced or eliminated.
- Shrinkage problems sometimes encountered with unseasoned solid timber are reduced or eliminated.
- Lightweight and easy to handle.
- Posi-JOIST® and Posi-PLUS® trusses may be trimmed to length on site.
- Load sharing ability.
- Strongback bracing increases floor stiffness and reduces squeaky floors.
- Optional top chord support reduces on-site labour.
- With Posi-Purlins, roof and ceiling can be fixed direct.
- Top chord hanging.

DEFINITIONS

Loadbearing Partition Walls - walls which carry roof and/or upper floor loads in addition to their own self weight and wall lining.

Non-Load bearing Partition Walls - walls which impart self weight only to supporting structure.

Platform Flooring - flooring fitted continuously from external wall to external wall prior to the installation of internal partition walls.

Fitted Flooring - flooring fitted for each room after internal walls have been installed.

Strongbacks - bracing members running at right angles to Posi-STRUTS® which provide load sharing between adjacent members.

LSD - Limit State Design.

FLOOR STIFFNESS

The dynamic response of floor systems to foot traffic and other moving loads is dependant on many factors such as the floor plan of supported walls, applied load, furniture layout, etc. The comfort and expectations of occupants also varies widely and is very personal.

Posi-STRUTS® have been designed so that the maximum span recommended in Tables 1 to 4 conforms to the vibration standard set out in AS1684.1-1999, Residential Timber-Framed Construction, Part 1 - design criteria.

When selecting a Posi-STRUT® for your application consideration should be given to the springiness of the floor. Generally the floor stiffness provided by the Tables meets the expectations of most occupants. Where Posi-STRUTS® are near their maximum span for large open areas like rumpus rooms and family rooms, or where additional floor stiffness is required the maximum spans given in Tables 1 to 6 should be reduced.

FLOOR LOADING

Posi-STRUTS® have been designed for the following Dead and Live Loads.

Dead Loads - are due to the mass of the structure and permanent fixtures. An allowance has been made in these designs for the following permanent loads:

Flooring - 22 mm Particle board flooring or equivalent plywood.

Ceiling - 13 mm plasterboard direct or 10 mm plasterboard on battens.

Floor covering - normal floor covering loads e.g. carpets or vinyl tiles. If, clay or heavy ceramic tiles are to be used, on large areas (i.e. greater than 3 square metres), further professional advice should be sought before commencing construction.

Live Loads - are temporary loads due to furniture or people which may vary over time.

Posi-STRUT® floor systems in this manual have been designed for 1.5 kPa which is suitable for domestic floor only. For commercial or public buildings seek advice from your Posi-STRUT® supplier.

Note: The Posi-STRUT® span chart tables attached, are not designed to support load bearing walls. All roof loads to be supported by external wall only. For Posi-STRUTS® that must support load bearing walls, contact your nearest MiTek office.

SPAN CHARTS FOR BOTTOM CHORD SUPPORT FLOOR TRUSSES

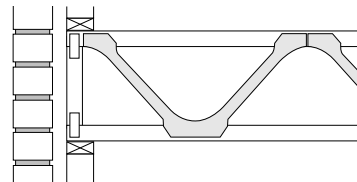

Note:

1. All charts designed using LSD method.
2. Minimum Joint Group JD5.

Maximum Spans for 35 mm thick timber

Posi-STRUT® Size	Timber Size (mm x mm)	Overall Depth (mm)	450 mm Posi-STRUT® Centres						600 mm Posi-STRUT® Centres							
			Timber Grade													
			F5	F8	F11	F17	MGP10	MGP12	MGP15	F5	F8	F11	F17	MGP10	MGP12	MGP15
PSW3520	35 x 70	197	1100	3800	4000	4400	3600*	4300	4600	-	3400	3700	4000	3100*	3800	4100
	35 x 90	197	3800	4200	4400	4800	4100	4600	4900	3300	3800	4000	4300	3400	4200	4300
PSW3525	35 x 70	248	2900*	4600	4900	5200	4200*	5100	5300	1100	4200	4400	4800	3400*	4700	4900
	35 x 90	248	4500	5000	5200	5500	4600	5400	5700	3900	4600	4800	5100	4100	5000	5200
PSW3530	35 x 70	302	3700*	5300	5400	5800	4600*	5700	5900	1100	4800	5000	5400	4100*	5300	5500
	35 x 90	302	5000	5600	5800	6200	5300	6100	6300	4400	5200	5400	5800	4500	5600	5900

*Important Note: For spans in the range of 1100 to 2600, top chords may require to be a minimum grade of F8 or MGP12 to conform to AS1720.1-1997.

Maximum Spans for 45 mm thick timber

Posi-STRUT® Size	Posi-JOIST® Size	Timber Size (mm x mm)	Overall Depth (mm)	450 mm Posi-STRUT® Centres						600 mm Posi-STRUT® Centres							
				Timber Grade													
				F5	F8	F11	F17	MGP10	MGP12	MGP15	F5	F8	F11	F17	MGP10	MGP12	MGP15
PSW4525	PJ25-70	45 x 70	248	4400	4900	5100	5400	4600	5300	5500	3800	4400	4600	5000	4000	4900	5100
	PJ25-90	45 x 90	248	4900	5200	5400	5800	5200	5600	5900	4300	4800	5000	5400	4500	5200	5500
PSW4530	PJ30-70	45 x 70	302	4900	5500	5700	6100	5200	6000	6200	4300	5100	5300	5700	4500	5500	5800
	PJ30-90	45 x 90	302	5500	5800	6000	6500	5800	6300	6600	4800	5400	5600	6000	5100	5900	6100
PSW4540	PJ40-70	45 x 70	412	5900	6500	6700	7200	6200	7100	7400	5200	6100	6300	6700	5500	6600	6800
	PJ40-90	45 x 90	412	6500	6900	7200	7700	7100	7500	7900	5600	6400	6700	7200	6100	7000	7300

SPAN CHARTS FOR TOP CHORD SUPPORT FLOOR TRUSSES

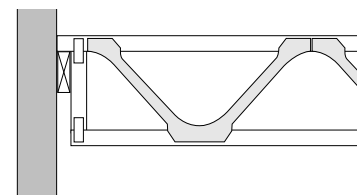

Note:

1. All charts designed using LSD method.
2. Minimum Joint Group JD5.
3. Spans have been produced for 45mm wide top chord bearings.

Maximum Spans for 35 mm thick timber

Posi-STRUT® Size	Timber Size (mm x mm)	Overall Depth (mm)	450 mm Posi-STRUT® Centres						600 mm Posi-STRUT® Centres							
			Timber Grade													
			F5	F8	F11	F17	MGP10	MGP12	MGP15	F5	F8	F11	F17	MGP10	MGP12	MGP15
PSW3520	35 x 70	197	-	3800	3800	4400	-	4200	4500	-	3000*	3600	3900	-	3800	3900
	35 x 90	197	1000	4000	4300	4600	4000	4600	4800	-	3600	3900	3900	-	3900	3900
PSW3525	35 x 70	248	-	4000	4700	5100	-	4900	5200	-	3000*	3700	4700	-	4500	4800
	35 x 90	248	3200#	4900	5000	5400	4600#	5300	5500	-	3900	4600	4900	3500#	4800	5100
PSW3530	35 x 70	302	-	4000	5000	5700	-	5500	5800	-	3000*	3700	5200	-	5100	5300
	35 x 90	302	3300#	5100	5600	6000	5200#	5900	6100	1100	3900	4800	5600	3900#	5400	5700

*Important Note: For spans in the range of 1100 to 2600, top chords may require to be a minimum grade of F11 or MGP12 to conform to AS1720.1-1997.

#Important Note: For spans in the range of 1100 to 2600, top chords may require to be a minimum grade of F8 or MGP12 to conform to AS1720.1-1997.

Maximum Spans for 45 mm thick timber

Posi-STRUT® Size	Timber Size (mm x mm)	Overall Depth (mm)	450 mm Posi-STRUT® Centres						600 mm Posi-STRUT® Centres							
			Timber Grade													
			F5	F8	F11	F17	MGP10	MGP12	MGP15	F5	F8	F11	F17	MGP10	MGP12	MGP15
PSW4525	45 x 70	248	4300	4700	4900	5300	4500	5200	5400	3700*	4300	4500	4900	3900	4800	5000
	45 x 90	248	4700	5100	5300	5600	5100	5500	5700	4200	4700	4800	5200	4500	5000	5200
PSW4530	45 x 70	302	4900	5300	5500	5900	5100	5800	6100	4200*	4900	5000	5500	4500	5300	5600
	45 x 90	302	5300	5700	5900	6300	5800	6200	6500	4700	5200	5400	5600	5000	5700	5600
PSW4540	45 x 70	412	4800*	6300	6500	6000	6100	6900	7200	-	5700	5900	6500	5400	6300	6600
	45 x 90	412	6300	6700	7000	7500	6900	7300	7700	5500	6100	6400	6900	5900	6700	6900

*Important Note: For spans in the range of 1100 to 2600, top chords may require to be a minimum grade of F8 or MGP12 to conform to AS1720.1-1997.

SUPPORTING STRUCTURE

The supporting structure should be checked to ensure that beams, walls and footings are capable of supporting all loads from floors and/or roof.

As Posi-STRUTS® allow the use of large open areas with fewer bracing walls, the stability of the structure should be checked in all cases.

1. Solid Brick Construction

Lateral stability and strength of supporting walls should be checked in accordance with Masonry Code AS3700-1998.

2. Timber Framed Construction

The strength and bracing of timber framed walls supporting Posi-STRUTS® should be checked using SAA Timber Framing Code AS1684-1999 or be designed using AS1720.1-1997.

3. Elevated Building

For traditional elevated buildings where a central row of piers is to be removed, additional bracing may be required to provide stability to the building. This may be provided by designing ground level shear walls at each end of the building, or by using braced partition walls located centrally. If in doubt, consult MiTek Australia Ltd.

In all of the above cases the stability of the structure relies to some extent on the bracing provided by the panel flooring. For this reason it is important that floor trusses be fixed securely to supporting walls.

All cross walls and end walls should be securely fastened to the outer supporting walls. For timber framed walls use a 50 x 100 mm Strapnail at each intersection. For masonry construction, a continuous timber top plate should be installed and joined to each intersecting top plate at cross walls using 50 x 100 mm Strapnails.

be attached to the timber chords, and not to the metal webs to avoid buckling.

When lifting Posi-STRUTS® with a crane, slings should be attached at panel points closest to the truss quarter points. See diagram.

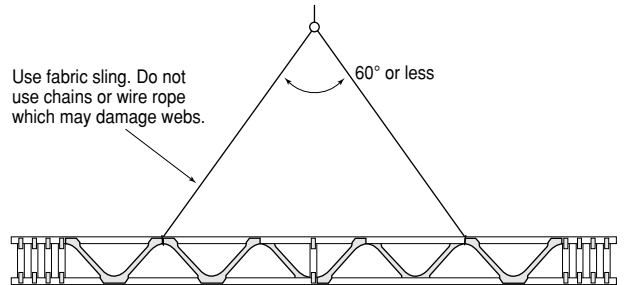
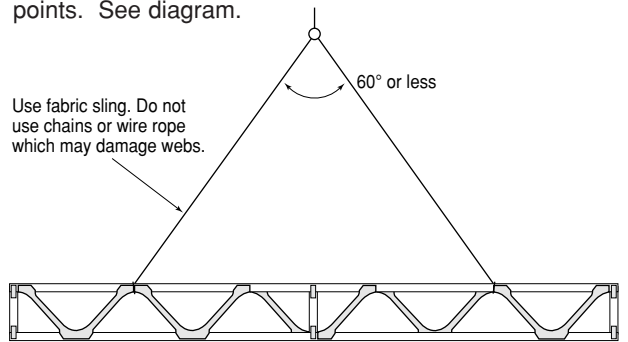

The maximum load of sheet materials temporary stored on the Posi-STRUTS is 250kg/m² and should not be greater than 300mm deep. This equates to 15 sheets of 19mm particle board, 13 sheets of 22mm particle board or 23 sheets of 13mm plasterboard. Where the sheets are stacked by hand they should span lengthways across the joists, (Fig. 1). When lifted mechanically they should be seated on 5 bearers the width of which are 600mm longer than the width of the board, (Figs. 2 & 3).

HANDLING AND STORAGE

All Posi-STRUT® components should be strapped and stacked vertically with the bottom chord clear of the ground, supported on bearers located directly under web points. Posi-STRUTS® may be stacked on top of each other with bearers aligned as closely as possible to web panel points.

Posi-STRUTS® should not be left exposed to weather for extended periods of time without adequate protection. If covered, ensure adequate air circulation around the trusses.

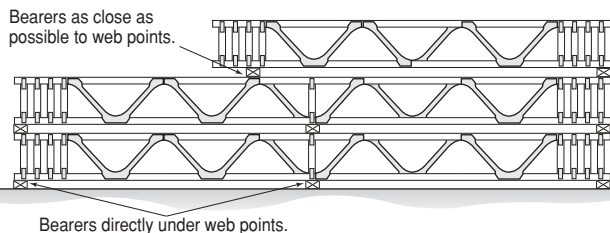
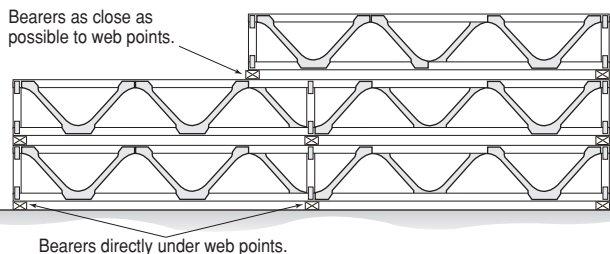

Typical stacking of Posi-STRUTS®

Care should be taken when handling the Posi-STRUT® to avoid bending, twisting or dropping. Slings should always

Fig. 1

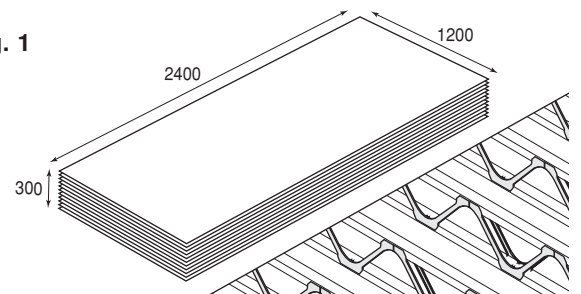

Fig. 2

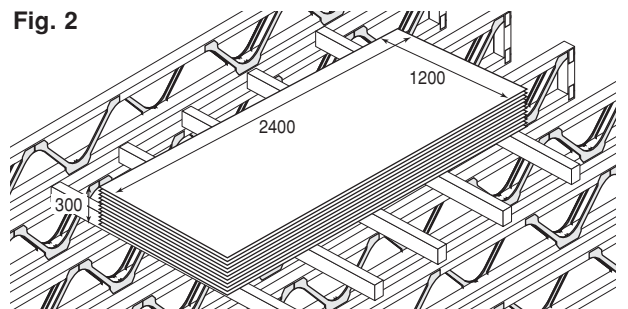
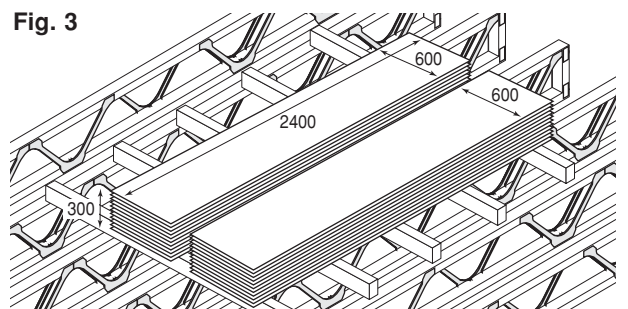

Fig. 3



SET OUT AND PLACEMENT

Posi-STRUTS® are generally placed perpendicular to load bearing supporting walls and should be located so that distance between them does not exceed the designed spacing.

Care should be taken to place the Posi-STRUTS® the right way up. Unless marked otherwise Posi-STRUTS® are always manufactured so that Posi-Web starts at the top chord at each support point. There are occasions where it is necessary to design and manufacture Posi-STRUTS® with the first web starting at bottom chord level. In this case trusses will be marked "THIS WAY UP".

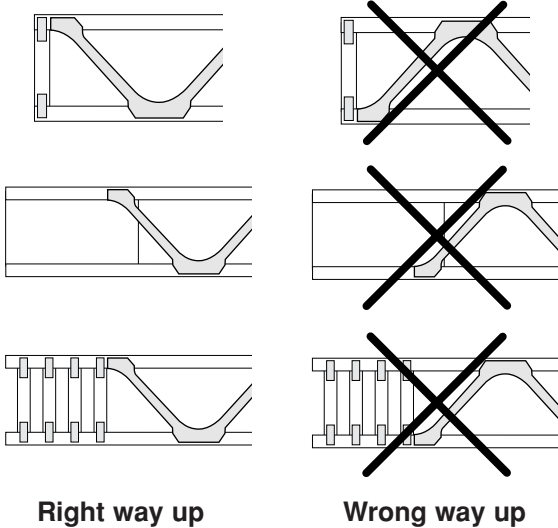

Right way up

Wrong way up

TRIMMING ON SITE

Only Posi-PLUS and Posi-JOIST members can be trimmed to length on site. Posi-TRUSSES are required to be manufactured to the required span for each project. If adjustments to span are required for Posi-TRUSSES you should consult with your supplier.

Trimming limitations for Posi-JOIST®

Posi-JOISTS® within the limits specified below may be trimmed each end by up to 335 mm for PJ20, PJ25 and PJ30 and up to 430 mm for PJ40. **Posi-JOISTS® should only be cut at locations between vertical webs.** The following procedure will allow trimming of Posi-JOISTS® to match your exact span.

- Where a supporting wall is to provide support to two abutting Posi-JOISTS®, position Posi-JOISTS® first so that there is equal bearing for each Posi-JOIST®. Also ensure that there is a vertical member located over the supporting wall.
- Check opposite support to ensure that a vertical timber web is also located over the support (allowable misplacement 5mm). Adjust location of truss until it is possible to trim without cutting through verticals.
- Use the first Posi-JOIST® as template for remaining trusses.

Note: Do not cut through vertical webs. It should only be necessary to cut at a position between vertical members.

Trimming limitations for Posi-PLUS®

Posi-PLUS® members may be trimmed at either end to within a minimum distance of 90 mm from the Posi-STRUT® web.

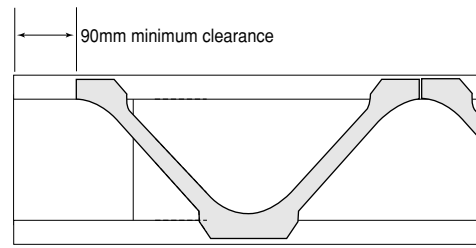

SUPPORTING EXTERNAL WALLS

CASE 1. Upper Storey of 2 Storey - for the upper storey of two storey construction, where the lower stud wall provides continuous support, and where wall plates and lintels have been sized in accordance with AS1684 lower storey load bearing walls, standard Posi-STRUTS® may be used to support upper walls where the effective length of roof supported does not exceed that given in Table 5. below.

Posi-STRUT® or Posi-JOIST® Size	Sheet Roof (mm)	Tile Roof (mm)
PSW3520	5,050	3,950
PSW3525	5,550	4,350
PSW3530	6,750	5,300
PSW4525	8,150	6,100
PSW4530	9,000	6,750
PSW4540	7,450	5,600

Note: The above table has been determined for sheet roof at 900mm centres and tiled roof at 600mm centres with maximum 25° roof pitch.

Where effective length of roof supported is greater than those in Table 5, F-Frame as specified below, solid bearer or standard Posi-STRUT® with timber verticals inserted under studs may be used.

F-Frame manufacturing details

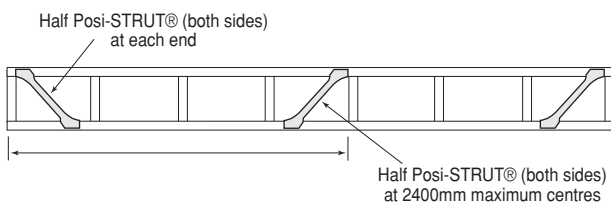

The sizes and grades of top and bottom chord of the F-Frame can be determined as per wall plates from AS1684 by adopting the vertical strut as stud spacing. Vertical struts do not necessarily have to line up with common studs if the wall plates have been designed accordingly.

Where there are larger openings in the upper storey wall which cause a concentrated load on the Posi-STRUT® or F-Frame, a suitable timber vertical member should be inserted between the top and bottom chord under the point load to transfer it down to the wall below.

- Note:** 1. Posi-STRUT® chords and F-Frame chords may be considered to act in conjunction with wall plates to form a double plate or ribbon plate.
2. Where openings are positioned in end walls, lintels are to be sized in accordance with AS1684.

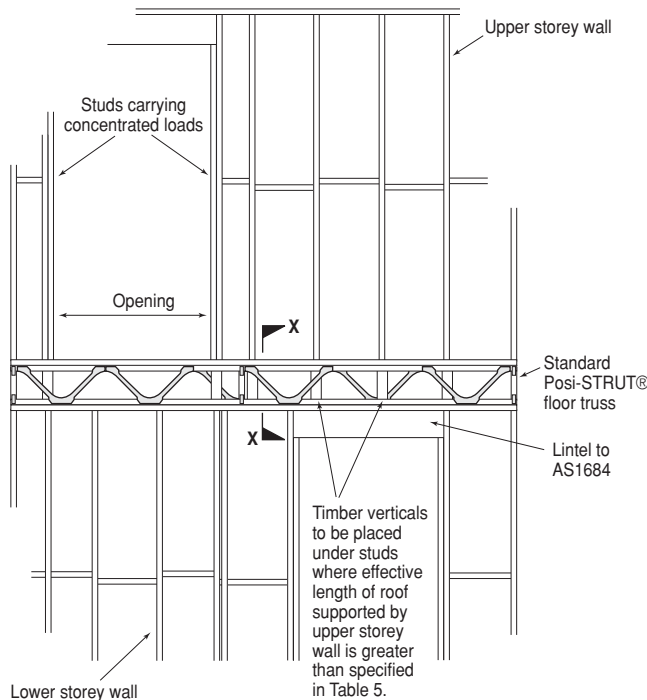

End wall - Upper Storey

SECTION X-X

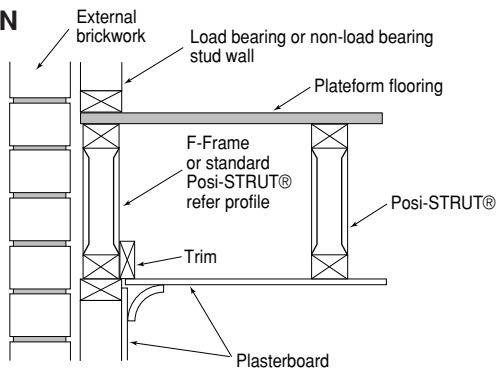

WARNING

Where stair wells or other voids are located adjacent external walls, the stability of the external wall should be checked by a structural engineer.

Generally, F-frames may be used to support upper walls of two storey construction at end walls where floor and ceiling acts as a diaphragm to restrain the external wall against lateral loads.

However, F-frames should not be used whenever supporting external walls that have an opening for a void area or staircase as shown. In these cases, the external walls are required to be designed by a structural engineer.

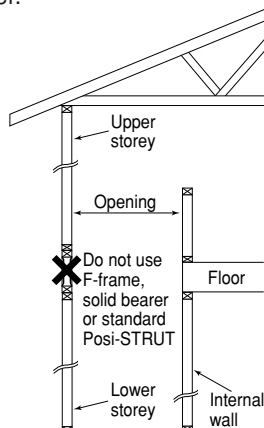

CASE 2. Single Storey - for a single storey construction where continuous support for the end F-Frame is not available, frames using Posi-JOIST® detail may be used provided the roof load (EL) does not exceed that specified in Table 6, and that pier spacing does not exceed 1200 centres.

Posi-JOIST® End Size	Sheet Roof (mm)	Tiled Roof (mm)
PJE25	7200	3600
PJE30	7200	3600
PJE40	7200	3600

Where the effective length of roof supported exceeds that specified in Table 6, use either solid timber or laminated ConstructaBEAMS to support end wall and roof loads. Bearer sizes to be taken from AS1684-1999, relevant State Timber Framing Code or refer Gang-Nail Span Charts for laminated ConstructaBEAMS or AutoBEAM.

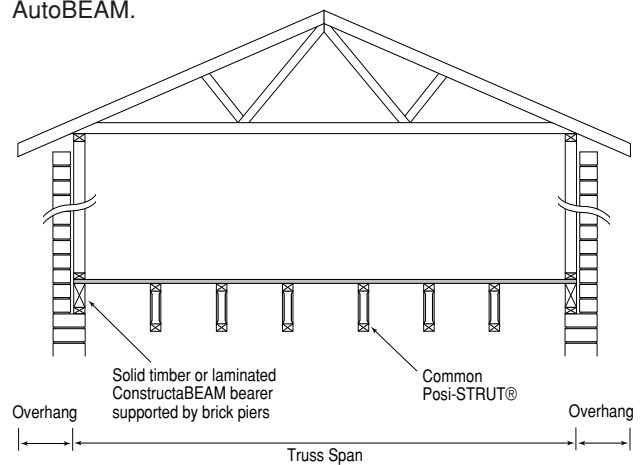

End wall - Single Storey

$EL = 2 \times \text{Overhang} + \text{Truss Span}$

Posi-JOIST END 25 (PJE25)

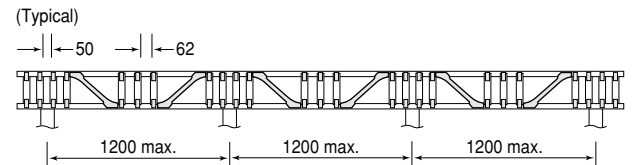

Posi-JOIST END 30 (PJE30)

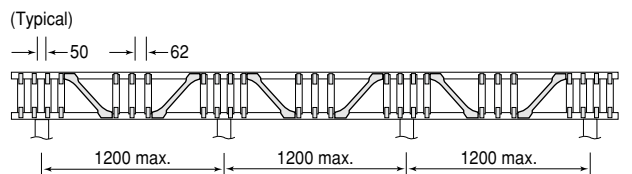

Posi-JOIST END 40 (PJE40)

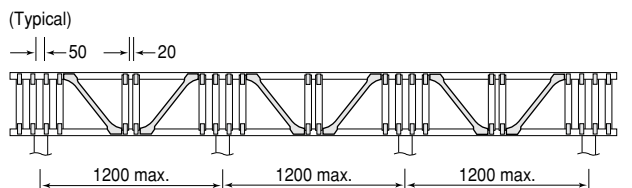

CASE 3. Building with Hip Ends - Both of the above two cases apply, provided the truncated girder truss station does not exceed the effective length of roof supported specified in Table 5.

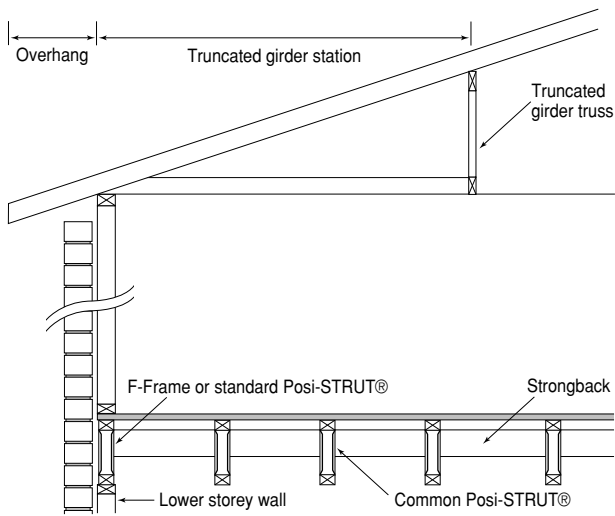

End wall - Building with Hip End Upper Storey of 2 storey

$EL = \text{Truncated Girder Truss Station} + 2 \times \text{Overhang}$

CASE 4. End Walls for Single Storey Buildings with Hip Roof - As for case 2 except $EL = \text{Truncated Girder Station}$.

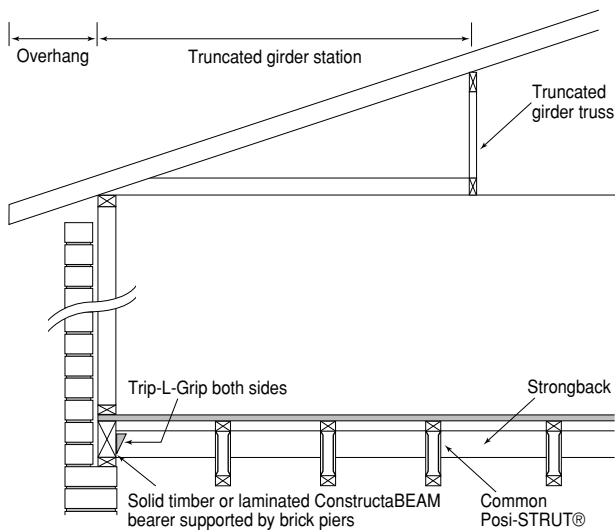

End wall - Building with Hip End Single Storey

$EL = \text{Truncated Girder Truss Station} + 2 \times \text{Overhang}$

CASE 5. End Walls for Buildings with Gable Roof - Similar to that of building with Hip End, except the effective length of roof supported is as follows:

$EL = 2 \times \text{Verge Overhang} + \text{Truss Spacing}$

SUPPORTING NON-LOAD BEARING WALLS

Walls Perpendicular to Posi-STRUTS®

Walls placed perpendicular to the Posi-STRUTS® require no additional support. However, for braced walls with bracing capacity of up to 3.0 kN/m and 2700mm high, fix each end of bracing wall using 2/90 x 35 F5 under battens with M10 bolt and washer.

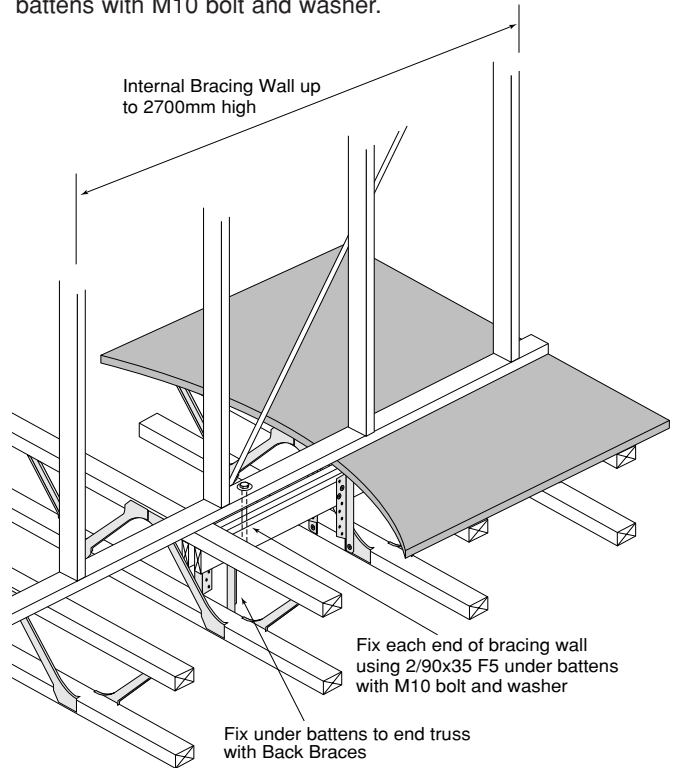

Braced walls perpendicular to trusses with bracing capacity up to 3.0 kN/m

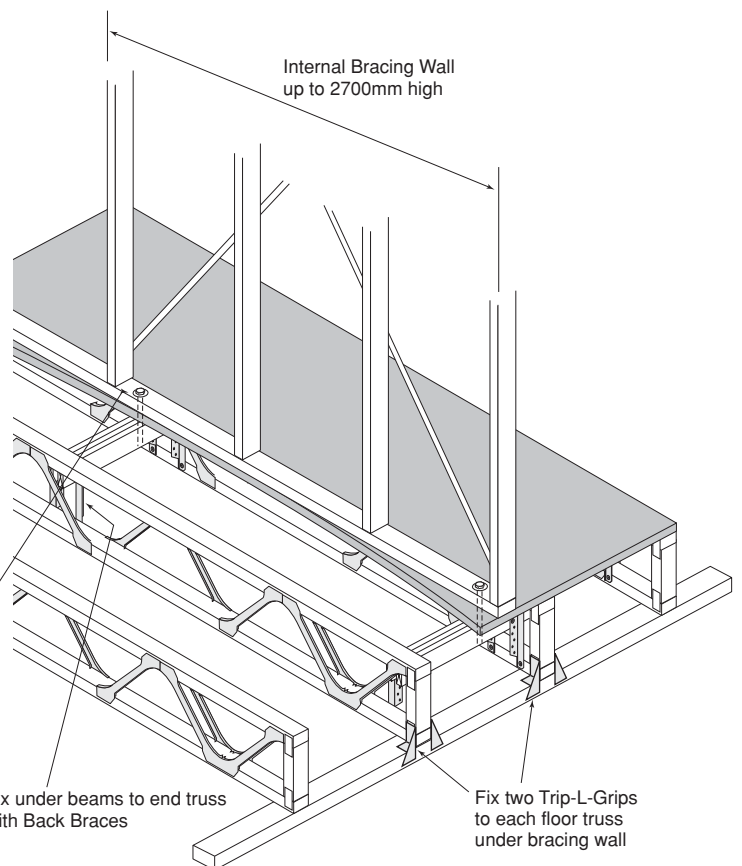

Bracing walls parallel to trusses with bracing capacity up to 3.0 kN/m

Walls Parallel to Posi-STRUTS®

a) Platform Flooring

Walls placed parallel to the Posi-STRUTS® do not require additional support where a platform floor is to be used and the flooring material is capable of supporting walls. However, for braced walls with bracing capacity of up to 3.0 kN/m and 2700mm high, fix each end of bracing wall using 2/90 x 35 F5 under battens with M10 bolt and washer.

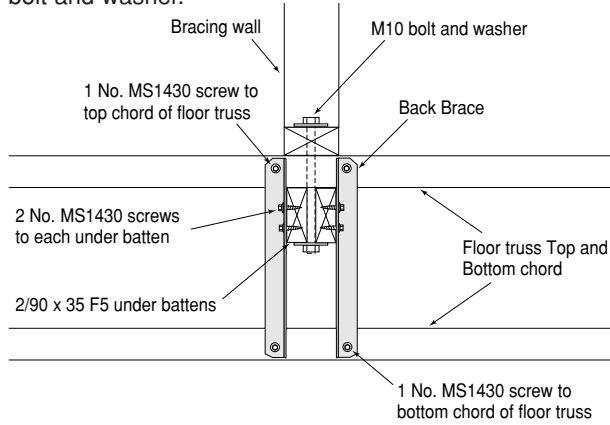

Under batten fixing detail

b) Fitted Flooring

Where flooring is fitted to each room after internal walls have been constructed, an additional truss is required below the wall to provide support to both the wall and flooring.

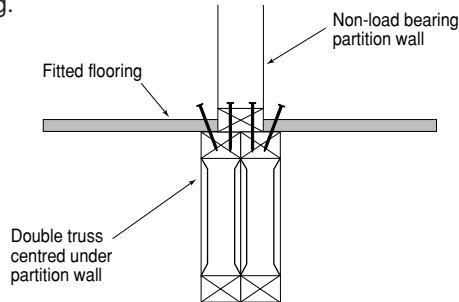

Fitted Flooring

Double trusses used under non-load bearing internal partition walls should be located such that the partition is bearing equally on both trusses. Flooring and strongbacks should be fixed to both trusses.

SUPPORT DETAILS

Posi-STRUT® Bottom Chord Support

Posi-STRUTS® may be supported on their bottom chord as shown

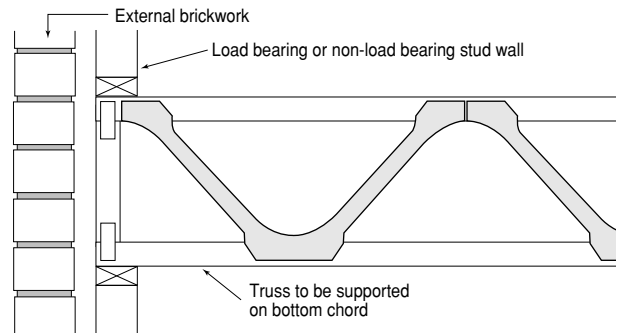
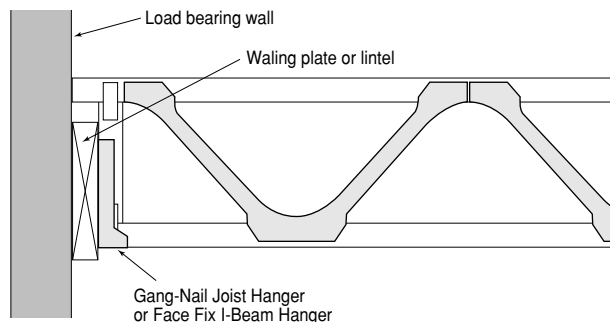

Posi-STRUT® Top Chord Support

The maximum span of top chord supported Posi-STRUTS® may be increased to the maximum span of the bottom chord trusses, if the end vertical web is fastened to the supporting beam with Gang-Nail Trip-L-Grips or if one of the following details are used:

1. Double end vertical web - see Figure 'X'.
2. Timber End Block - see Figure 'Y'.

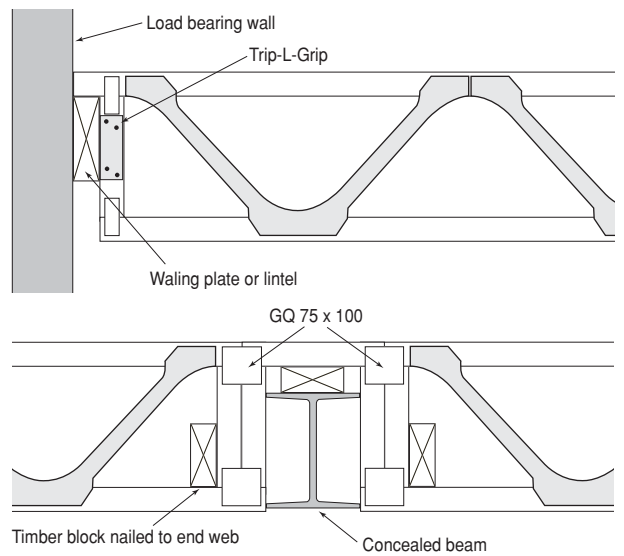

Figure 'X'

Recommended Timber Blocking Sizes				
Posi-STRUT Depth	200	250	300	400
Strongback Size	90 x 35	120 x 35	140 x 35	190 x 35

Timber End Block for Top Chord Supported Posi-STRUTS®

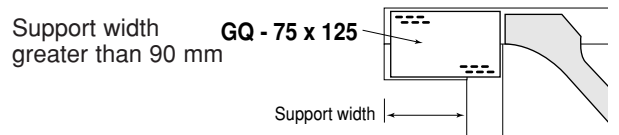
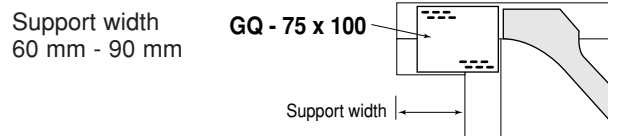
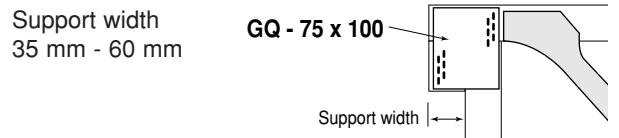
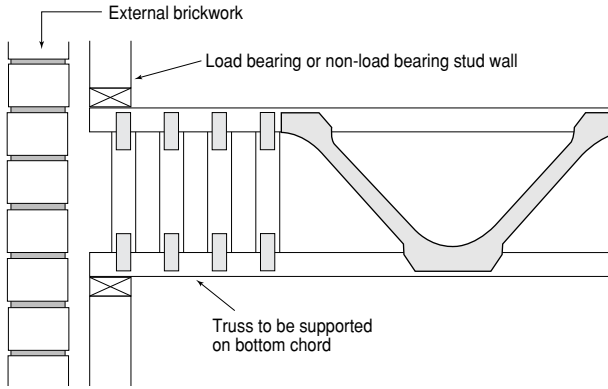

Figure 'Y'.

Posi-JOIST® Bottom Chord Support

Posi-JOISTS® should only be supported on their bottom chord as shown.



Posi-PLUS® Bottom Chord Support

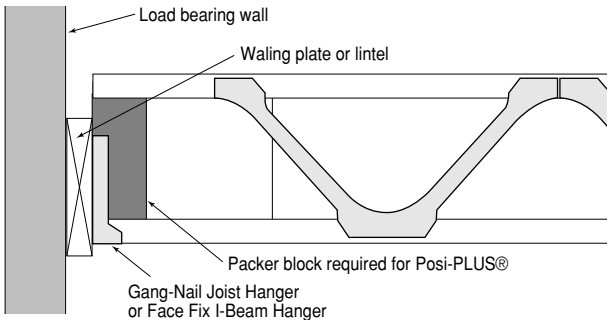

Posi-JOIST® Top Chord Support

Where it is necessary to support Posi-JOISTS® by the top chord as shown, Trip-L-Grip's are required to fasten the truss end vertical web to face of the supporting beam

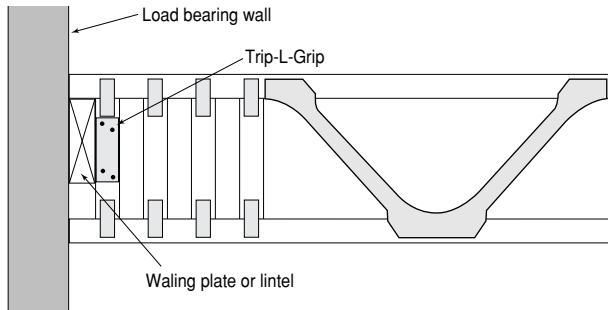

Hangers for Floor Trusses

Floor trusses may be supported by Joist Hangers or I-Beam Hangers in accordance with MiTek 20/20 fixing schedule.

FIXING AND CONNECTIONS

Fixing to External Walls

Each Posi-TRUSS® to be fixed onto the supporting structure by a minimum of 2 / 3.15 mm diameter x 75 mm long nails. For wind classification areas higher than N2 refer to AS1684 for details.

Posi-STRUT®

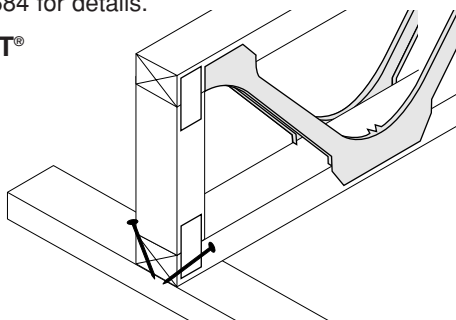

Posi-JOIST®

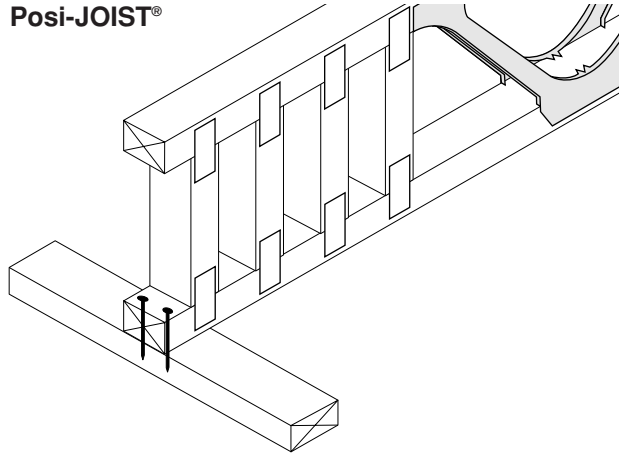

Fixing to Internal Walls

When Posi-STRUTS® are to be supported by internal walls place Posi-STRUTS® side by side and fix as above or butt together using a 50 x 100 mm Strapnail to connect Posi-STRUTS®.

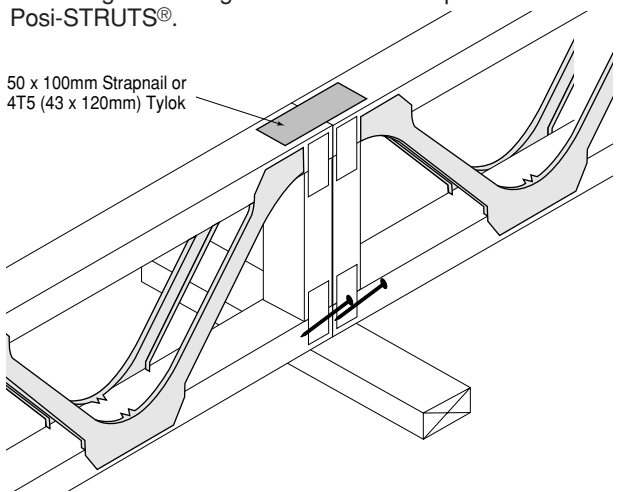

Support of Internal Load Bearing Walls

Posi-STRUTS® are generally not designed to support load bearing internal walls, however where there is a supporting wall directly below, Posi-JOIST® and Posi-PLUS® trusses should be strengthened as illustrated below.

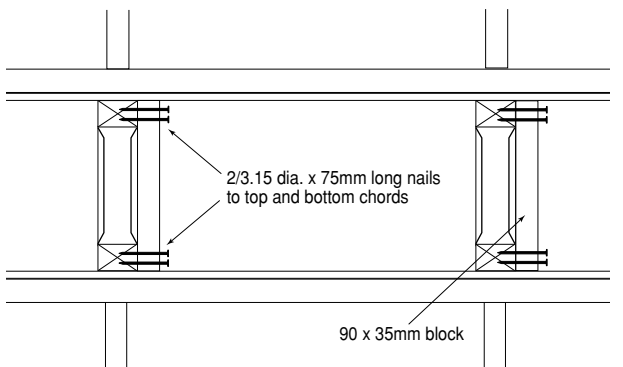
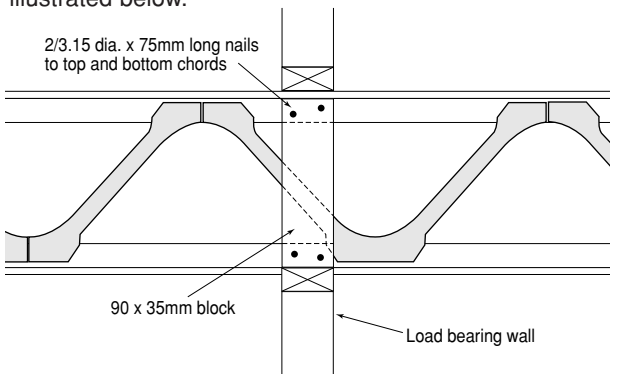

Fixing to Internal Walls

a) Non-bracing wall

If internal walls are not designed as bracing walls, fix the truss with the INTERNAL WALL BRACKET with nails at the top of the slots to allow for truss settlement as it is loaded. Brackets are fixed at 1.8m centres along unsupported sections of the wall. Where trusses are parallel to walls, trim between the bottom chords and fix brackets to the trimmer. Where internal walls are stable in their own right, no Internal Wall Brackets are required.

Truss Parallel to Non-Bracing Wall

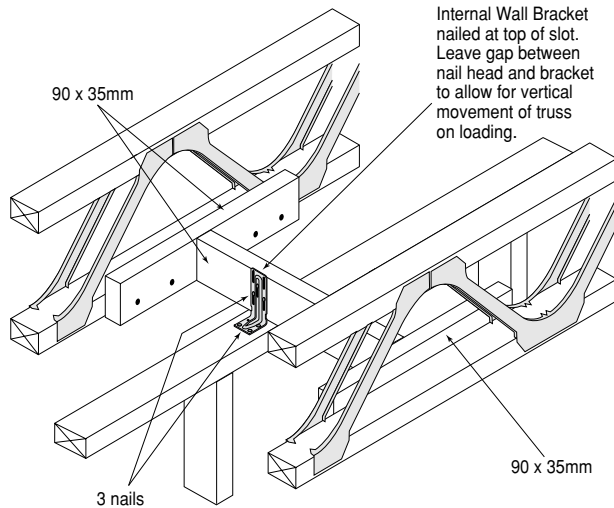

Truss Perpendicular to Non-Bracing Wall

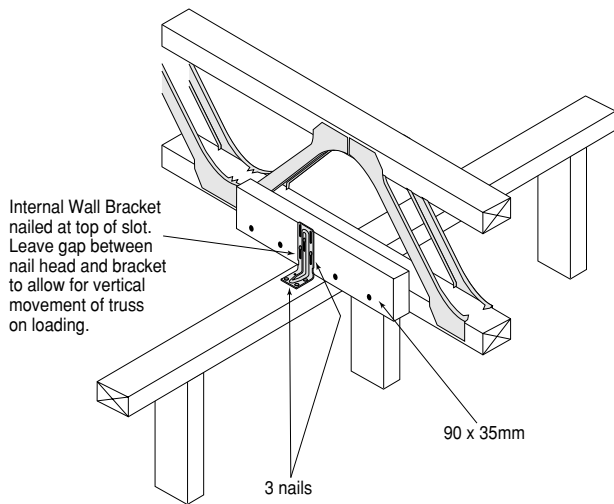

b) Bracing Wall

Where internal walls are designed as bracing walls, trusses should be fixed to the top plate using structural connections of equivalent strength to the bracing strength of that particular bracing wall. The connection should also allow the truss to deflect vertically when it is loaded.

Truss Parallel to Bracing Wall

Nailing plates or framing anchor (legs not bent) to either end of nogging with 6/2.8mm diameter nails to each face.

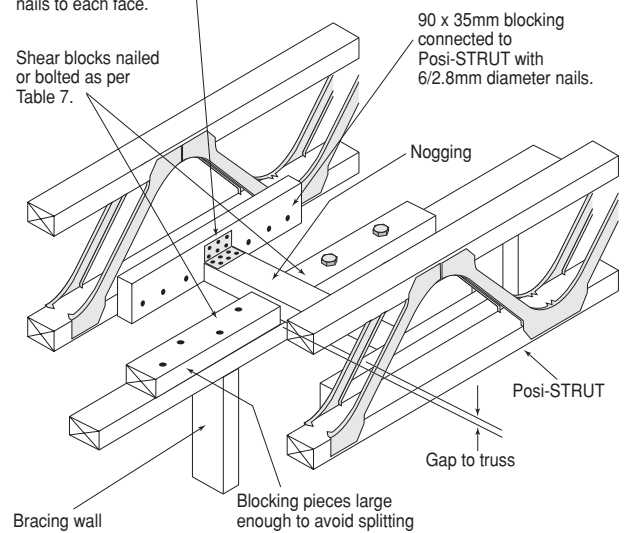

Truss Perpendicular to Bracing Wall

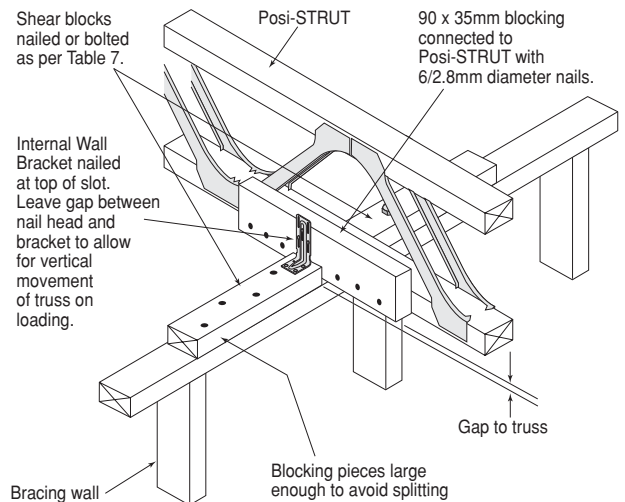

Table 7 - Fixing details for Bracing Walls

Type of Connection	Number of Type A or Type B bracing units in braced wall (Refer AS1684 Part 4)											
	Unseasoned Timber						Seasoned Timber					
	J2		J3		J4		JD4		JD5		JD6	
Type A	Type B	Type A	Type B	Type A	Type B	Type A	Type B	Type A	Type B	Type A	Type B	
Nails												
4/3.05ø	1.6	N	1.1	N	N	N	1.1	N	N	N	N	N
6/3.05ø	2.1	1.1	1.5	N	1.1	N	1.6	N	1.2	N	1.0	N
4/3.33ø	1.9	N	1.3	N	N	N	1.3	N	1.1	N	N	N
6/3.33ø	2.4	1.2	1.7	N	1.2	N	1.8	N	1.5	N	1.1	N
Bolt Size												
M10	2.5	1.3	2.2	1.1	1.7	N	2.0	1.0	1.6	N	1.3	N
M12	3.3	1.6	2.6	1.3	2.1	1.0	2.4	1.2	1.9	1.0	1.5	N
Screws												
2 No.14 Type 17	3.2	1.6	2.3	1.2	1.6	N	2.3	1.2	1.6	N	1.2	N
3 No.14 Type 17	5	2.5	3.3	1.7	2.5	1.2	3.3	1.7	2.5	1.2	1.8	N

N - Not Suitable

Fixing to Steel Beam

Note:

1. Size of packers and timber fixing plate to suit steel flange width.
2. Timber fixing plate is to be contained within the steel beam flange so as to restrain any vertical loads induced by Posi-STRUT® trusses.

Posi-TRUSS®

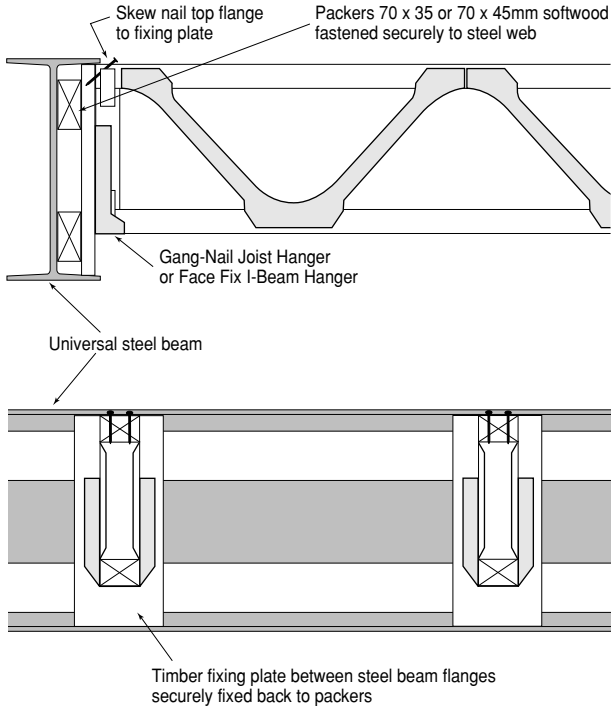

Posi-PLUS®

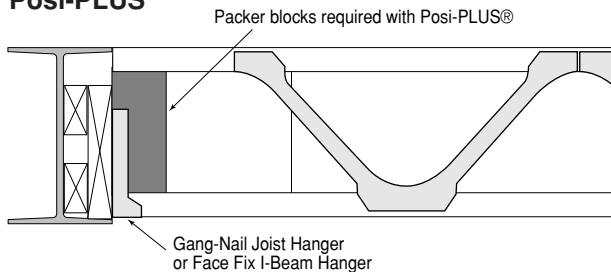

Notched Posi-PLUS® to Steel Beam

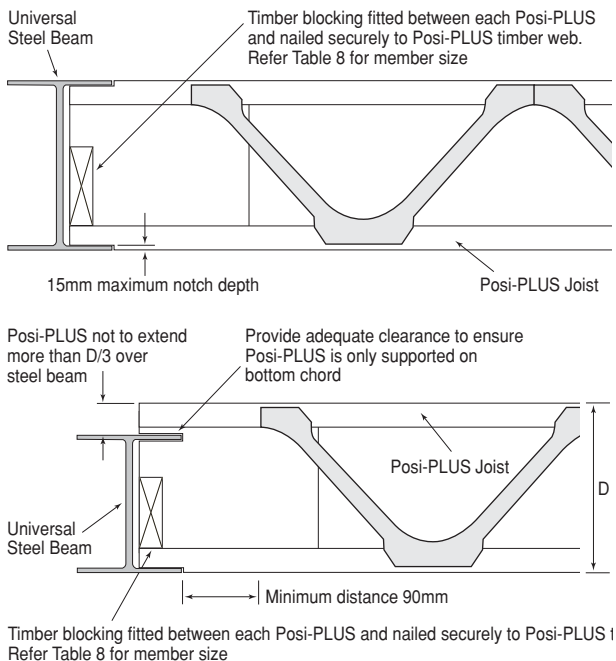

Timber blocking fitted between each Posi-PLUS and nailed securely to Posi-PLUS timber web. Refer Table 8 for member size

Table 8. Timber Blocking Size Required

Posi-PLUS®	Timber Blocking Size
PP 250 deep	120 x 35
PP 300 deep	140 x 35

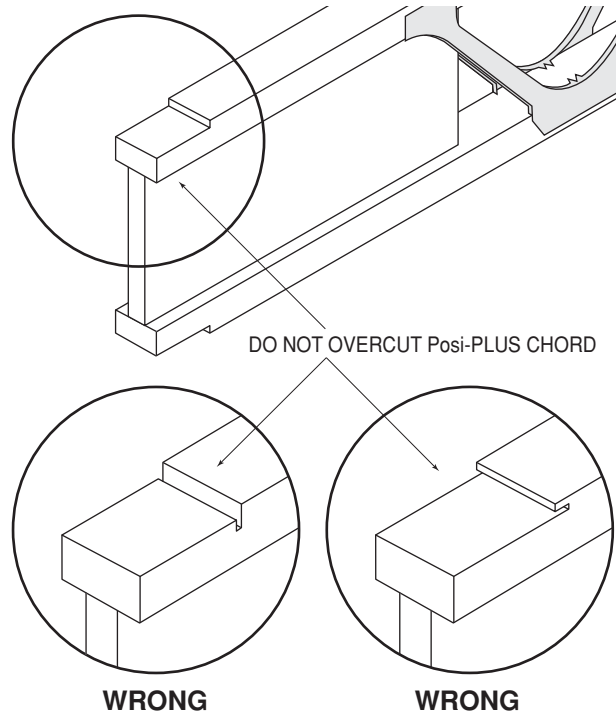

STRONGBACKS

Strongbacks are bracing members running at right angles to Posi-STRUTS®. Strongbacks significantly dampen vibrations and increase the stiffness of the floor system. The performance of the floor depends very much on the proper installation of strongbacks. Strongbacks to be supported off end walls and any internal walls to increase floor stiffness. They should be placed at 2400mm maximum spacing along span of each truss.

Strongbacks must be fixed to the central vertical webs on each Posi-STRUT® with 3/3.15 mm diameter nails and spliced in accordance with details following.

The ends of strongbacks (and wherever internal partitions are crossed) should be anchored to the wall to improve dynamics with nominal fixing as required for ceiling joists in AS1684.

Note:

1. Timber grades for strongback sizes given in the above table to be equivalent to or higher than grade used for Posi-STRUT® chord sizes.
2. Alternatively a deeper section strongback of a lower grade may be used. Reduce by one grade for each 25mm increase in depth.
3. Table 9 applies to standard design charts in this document only. Where Posi-STRUT® trusses are custom designed using MiTek20/20 software, strongback sizes specified by MiTek20/20 computations should be used.
4. It is recommended strongbacks be used to align trusses during installation by locating the strongback hard against the underside of truss top chord or top of bottom chord before fixing to timber web or Back Brace.

Posi-STRUT Depth	200	250	300	400
Strongback Size	90 x 35	120 x 35	140 x 35	190 x 35

Strongback fixing and splice

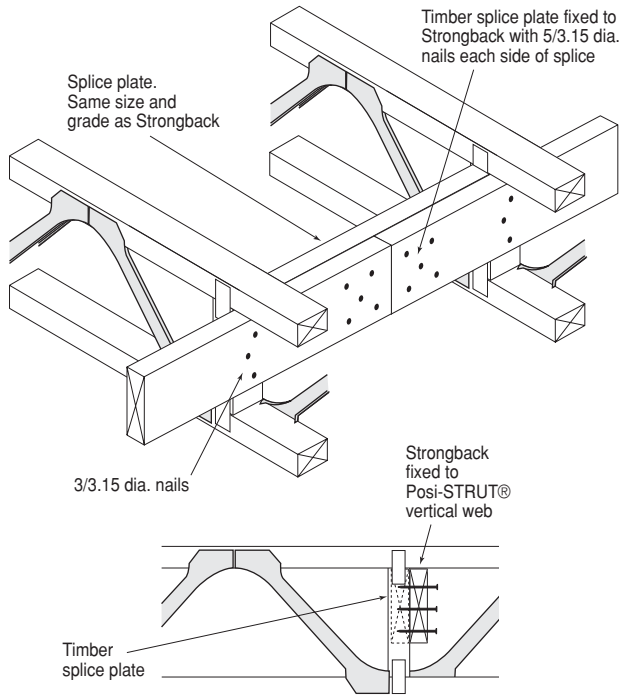

Strongback to double truss connection

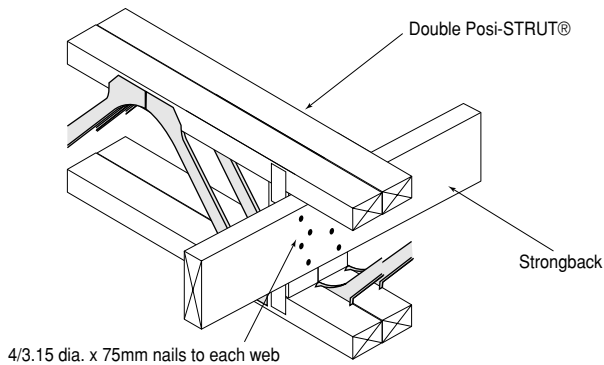

Alternative strongback splice

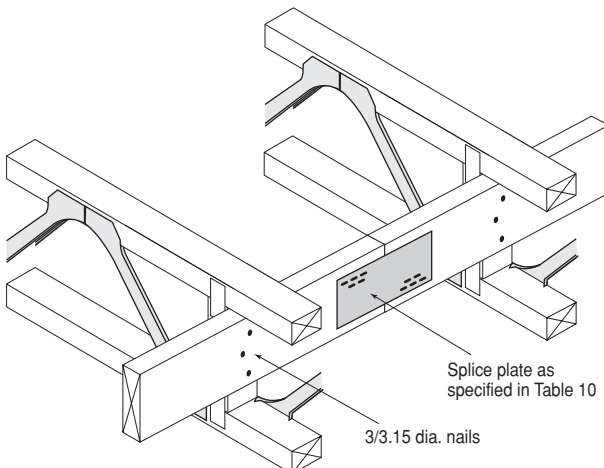

Strongback Size	Joint Type	GN Plate Type & Size	Tylok Plate Type & Size
90 x 35	Single	GE75150	6T10
120 x 35	Single	GE75150	6T10
140 x 35	Double	GQ50150	6T5
190 x 35	Double	GQ63150	8T7

When strongback location changes, the strongback must run through to the next Posi-STRUT® and be connected to the side as per detail following.

Connection of strongback to Posi-STRUT® at change of span

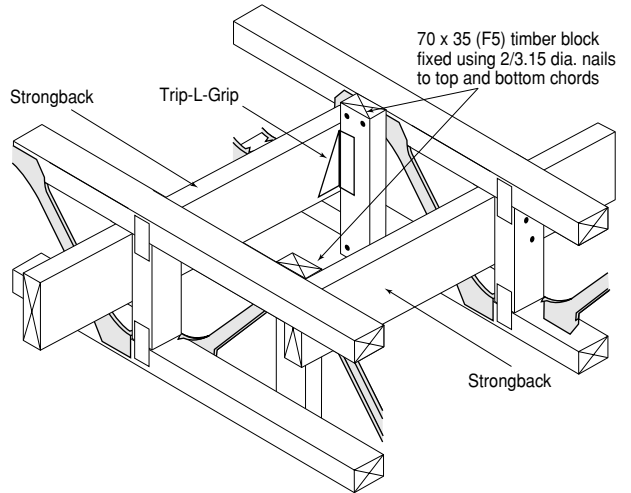

Strongback fixing using Gang-Nail Back Brace bracket

The Back Brace allows the strongback to be fixed at positions other than at timber vertical webs. This enables the strongback to be fixed in a continuous line when there are variations in span.

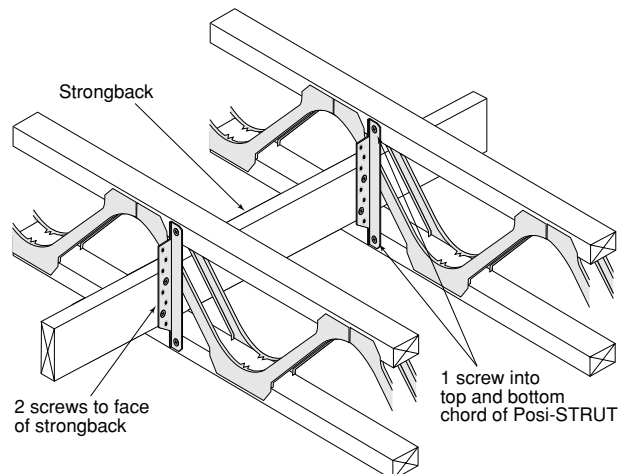

Note:

1. All screws MiTek 14 gauge x 30mm.
2. Do not over tighten screws.

STAIR OPENINGS

Where openings are required on the upper floor for stairwells, one or more shorter Posi-STRUTS® may be used and supported on headers fixed to adjacent Posi-STRUTS®.

The header beam maybe supported on double Posi-STRUTS® as shown below. For header beam sizes refer Table 11. The connection of the header to the double Posi-STRUT® is as shown on page 15.

Note that header beams have been designed to carry Posi-STRUT® floor loads only.

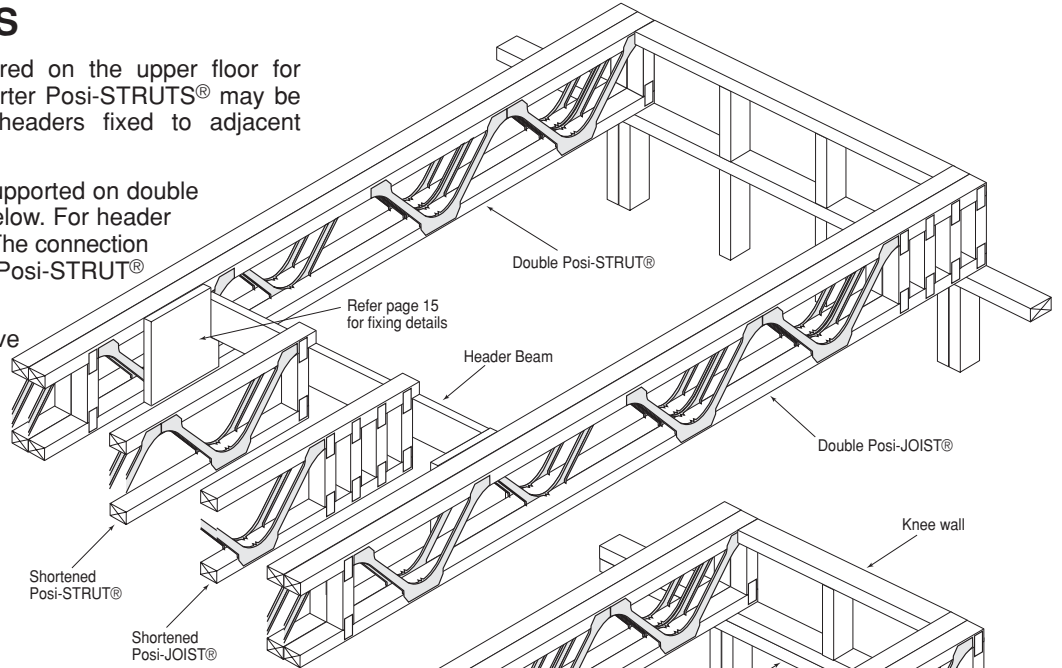

Note:

Posi-JOIST to be supported by fixing end vertical web as specified on page 10.

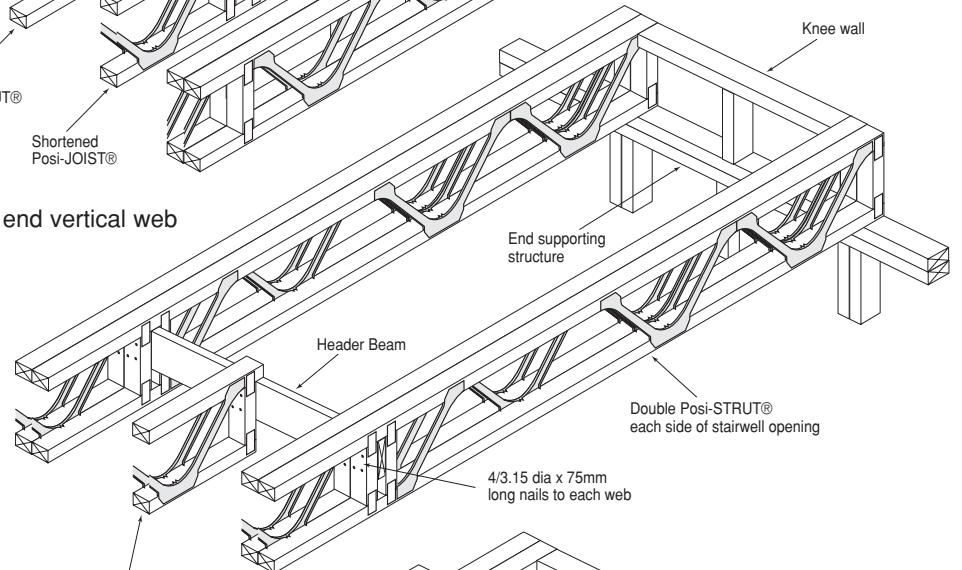

Posi-PLUS® Header Beam Fixing Detail

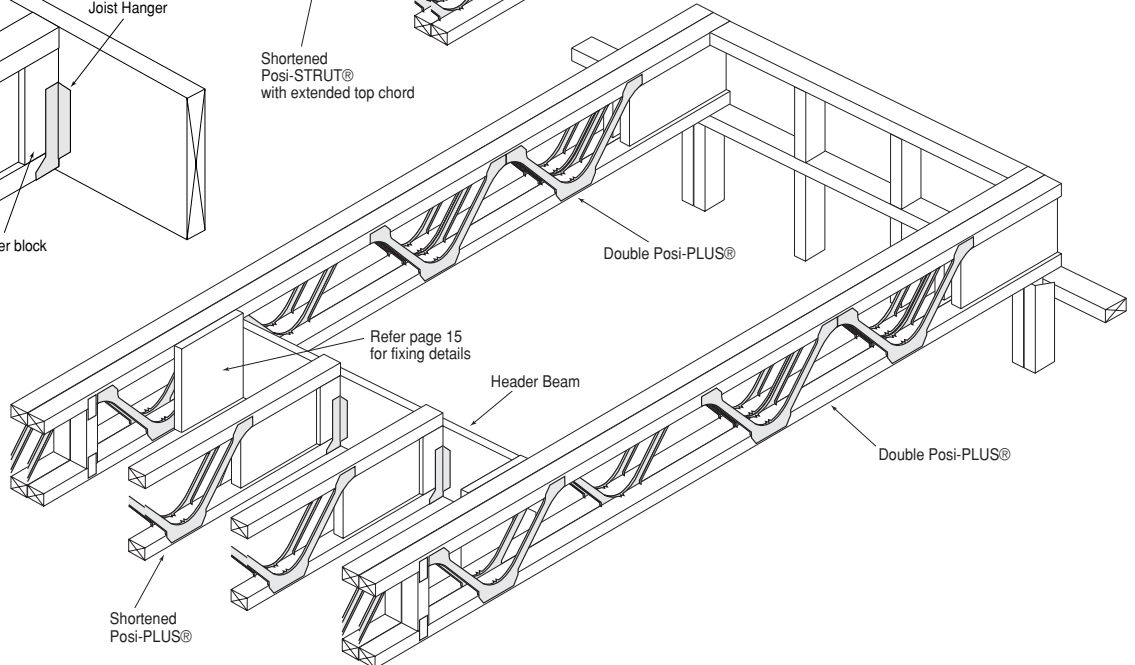
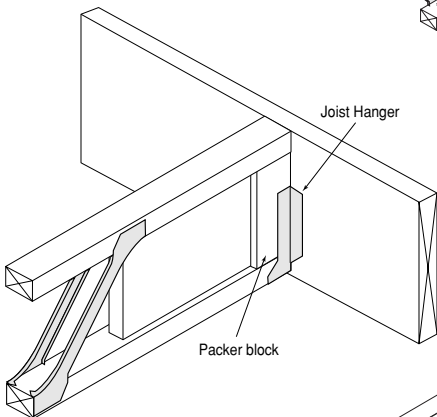

Table 11. Header Beam Sizes to Support Posi-STRUTS® Only

Shortened Truss Span	Header Beam Span (mm)						
	900	1200	1500	1800	2100	2400	2700
2000	90 x 45 (F5)	90 x 45 (F5)	90 x 45 (F17)	120 x 45 (F8)	140 x 35 (F8)	190 x 35 (F8)	190 x 35 (F8)
3000	90 x 45 (F5)	90 x 45 (F8)	120 x 35 (F8)	140 x 35 (F17)	140 x 35 (F17)	190 x 35 (F8)	190 x 45 (F8)
4000	90 x 45 (F5)	90 x 45 (F17)	120 x 45 (F8)	140 x 45 (F17)	140 x 45 (F17)	190 x 45 (F8)	190 x 45 (F17)
5000	90 x 45 (F5)	90 x 45 (F17)	120 x 35 (F17)	140 x 45 (F17)	190 x 45 (F17)	190 x 45 (F17)	240 x 35 (F17)
6000	90 x 45 (F5)	120 x 35 (F17)	120 x 45 (F17)	140 x 45 (F17)	190 x 45 (F17)	190 x 45 (F17)	240 x 35 (F17)

Illustrated below are some common types of stairwells (refer to Figures 1 to 3). For each diagram there are certain conditions that need to be observed.

For other types of stairwells, and for dimensions greater than those shown in Figures 1 to 3, contact your Posi-STRUT® supplier.

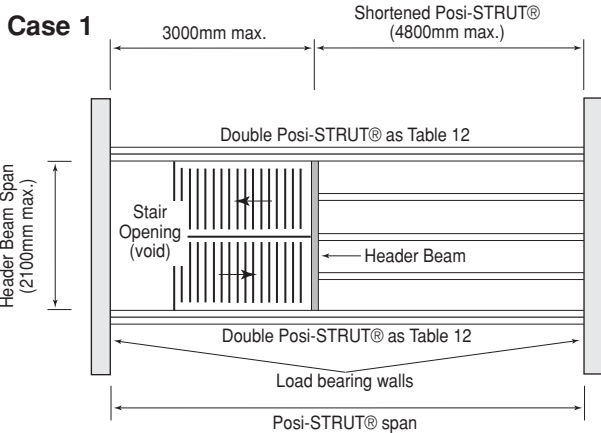

Figure 1

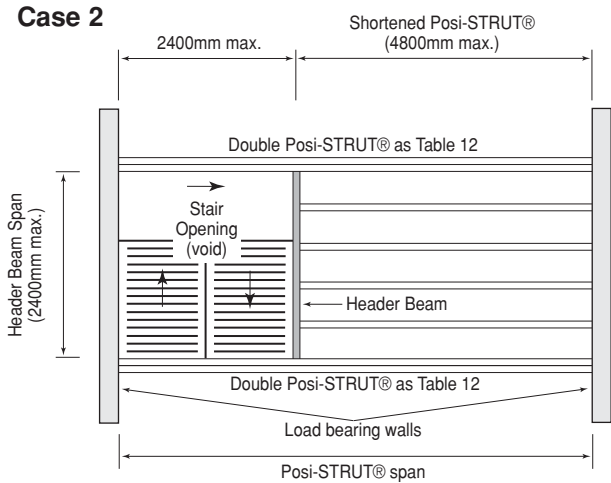

Figure 2

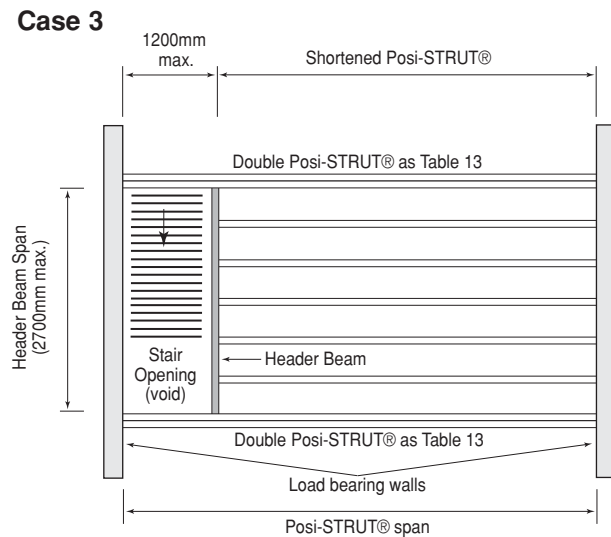

Figure 3

Note:

1. These double Posi-STRUTS® have been designed to carry header beams which support shorter Posi-STRUTS® only. They will not carry the stairwell itself.
2. Double Posi-STRUTS® have also been designed for 600mm maximum truss centres. Therefore, web layouts of 600mm truss centres should be used.

Table 12. Maximum Spans for double Posi-STRUTS® Case 1 and Case 2 Supporting Header Beam (mm)

Posi-STRUT® Size	Timber Size (mm x mm)	Timber Grade		
		F5	F8	F17
PSW3520	35 x 70	-	3500	4100
	35 x 90	3400	3800	4200
PSW3525	35 x 70	3500	4100	4500
	35 x 90	3800	4500	4500
PSW3530	35 x 70	3800	4600	4600
	35 x 90	4100	4600	4600
PSW4525	45 x 70	3900	4600	4900
	45 x 90	4100	4900	4900
PSW4530	45 x 70	4100	4900	4900
	45 x 90	4600	4900	4900
PSW4540	45 x 70	4800	5300	5400
	45 x 90	5200	5400	5400

Table 13. Maximum Spans for double Posi-STRUTS® Case 3 Supporting Header Beam (mm)

Posi-STRUT® Size	Timber Size (mm x mm)	Timber Grade		
		F5	F8	F17
PSW3520	35 x 70	-	2900	2900
	35 x 90	2800	2900	2900
PSW3525	35 x 70	2800	2900	2900
	35 x 90	2900	2900	2900
PSW3530	35 x 70	2900	3000	3000
	35 x 90	3000	3000	3000
PSW4525	45 x 70	3000	3600	3600
	45 x 90	3400	3600	3600
PSW4530	45 x 70	3200	3600	3600
	45 x 90	3600	3600	3600
PSW4540	45 x 70	3800	4200	4200
	45 x 90	4200	4200	4200

Header Beam Connection

Where double Posi-STRUTS® are supporting header beams, strongbacks are to be fixed to each truss using 4/3.15 mm diameter x 75 mm long nails.

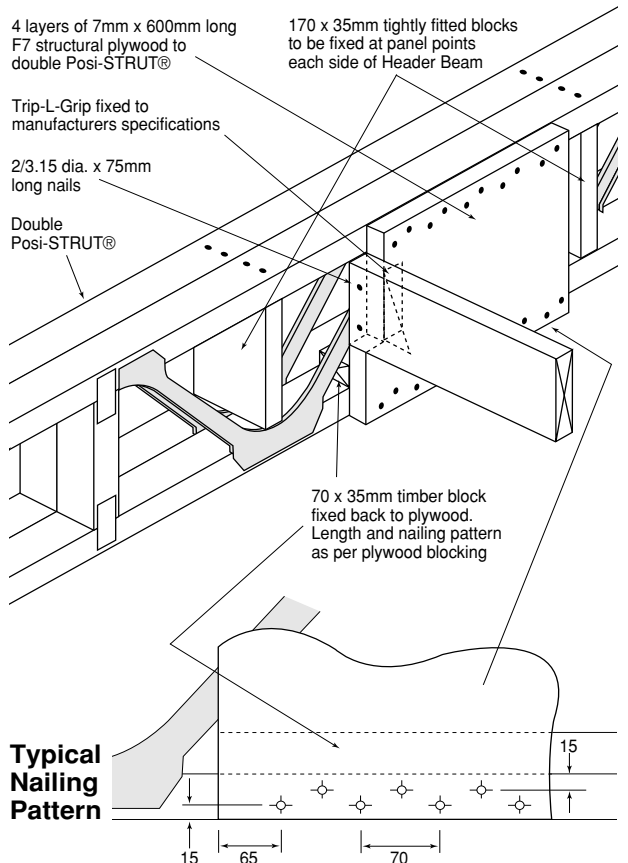

CANTILEVERS

Non Load Bearing Wall

Cantilevered balconies can be formed using solid timber either fitted into trusses between chords or off to the side of the truss as shown below. The cantilever beam can be sized from timber span charts and should extend back into the building to a distance greater than the balcony length. Balcony cantilevers should be no greater than one fifth of the floor truss span.

For cantilever beams built into Posi-STRUT® trusses ensure full bearing along top and bottom chord using suitable dry timber packers fixed to both truss and beam with 3.15mm dia. nails at 225mm centres.

For beams supplied separate to trusses, fix to vertical webs with a minimum of 3/3.15mm dia. nails and to the first strongback with 1 Trip-L-Grip. Provide lateral ties to top edge of beam at 600mm centres fixed to beam with 1/3.15mm dia. nail.

Built in cantilever beam.

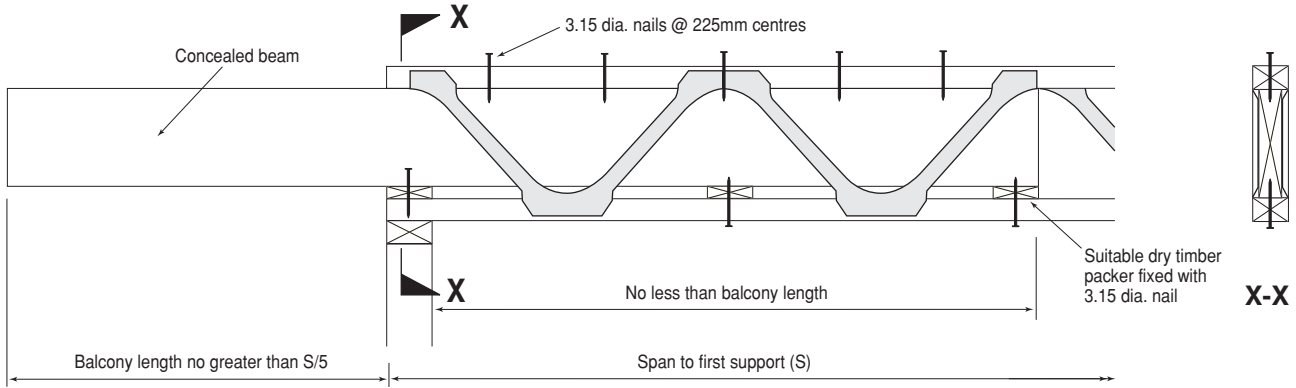

Lapped and nailed cantilever beam.

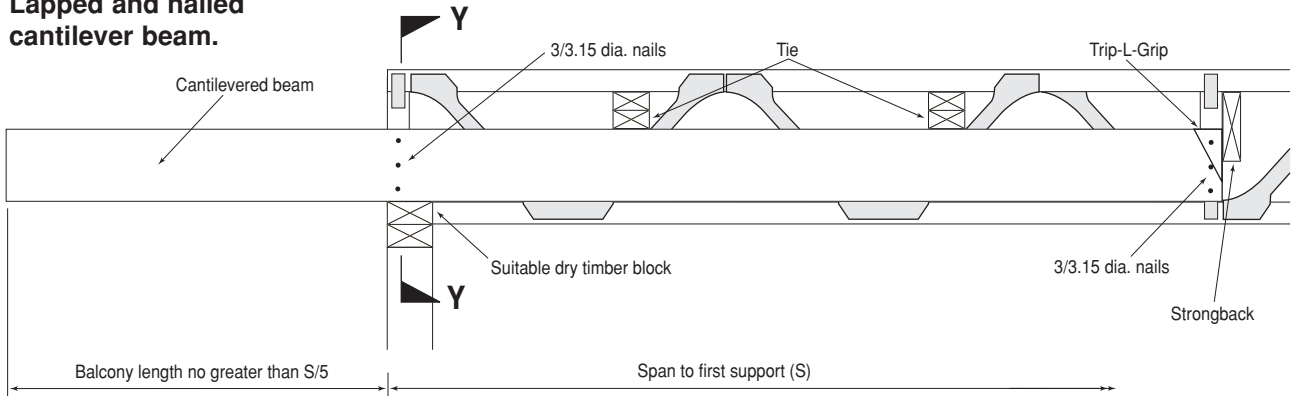

Note:

1. Cantilever beam has been designed to carry balcony load only. Size and grade can be obtained from AS1684.
2. If cantilever is exposed to weather, place damp proof course between joist and Posi-TRUSS®.

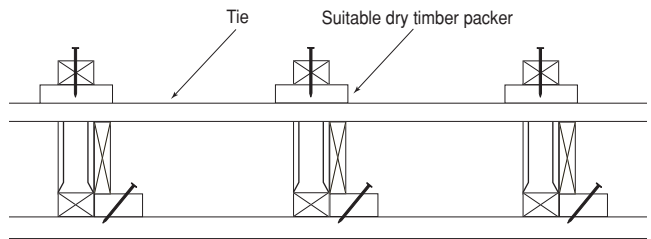

SECTION Y-Y

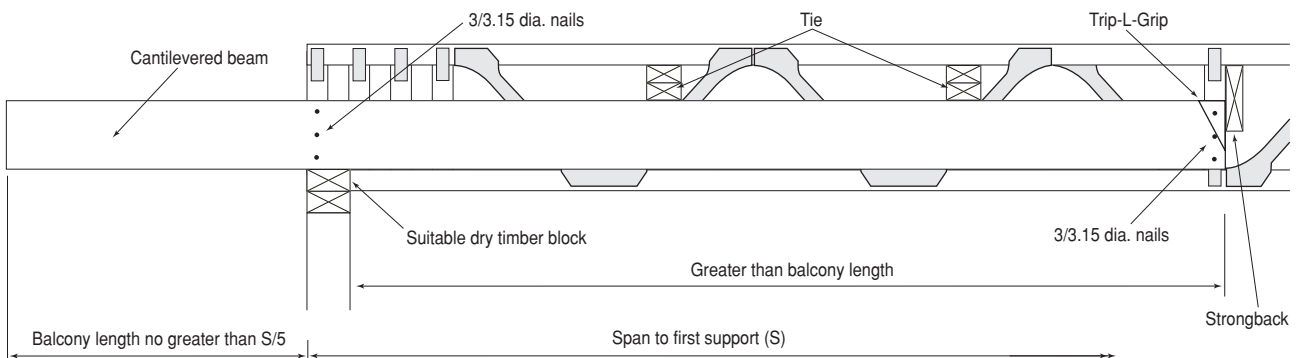

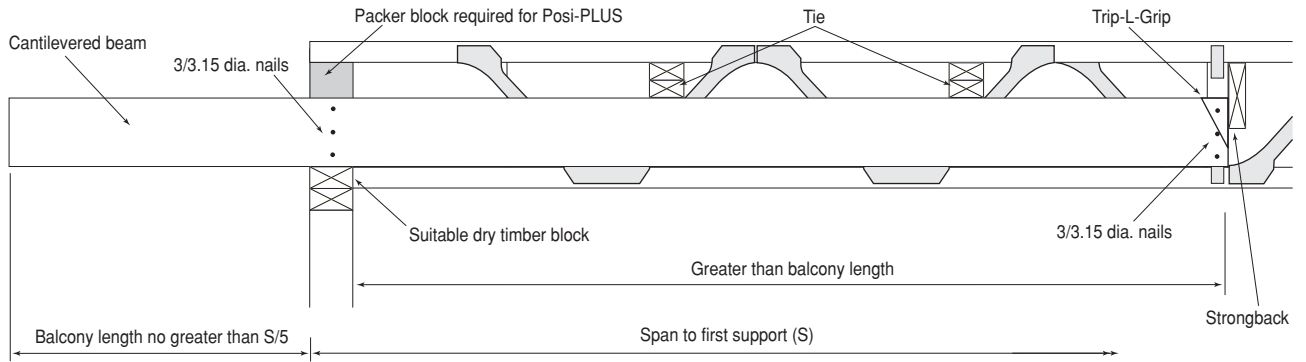

Load Bearing Wall

Posi-PLUS®

Standard Posi-PLUS® trusses may support an external load bearing wall on a cantilever provided that the cantilever does not exceed 160mm and maximum standard roof truss span does not exceed 12m for both sheet and tile roof. Wall cladding of 30kg/m² maximum is also allowed for.

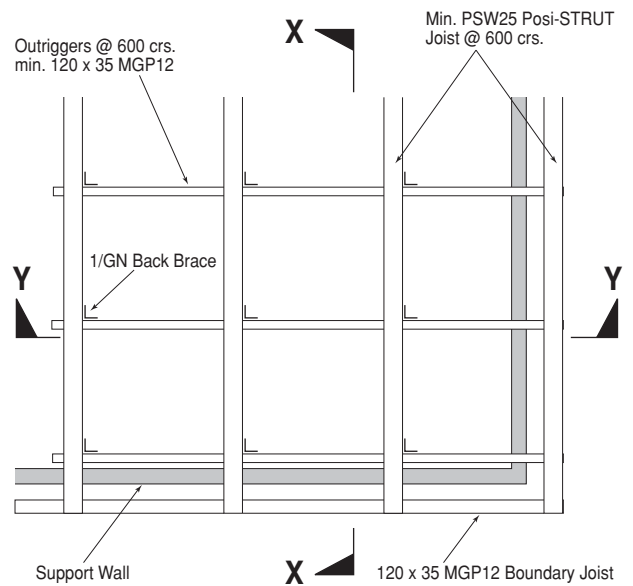
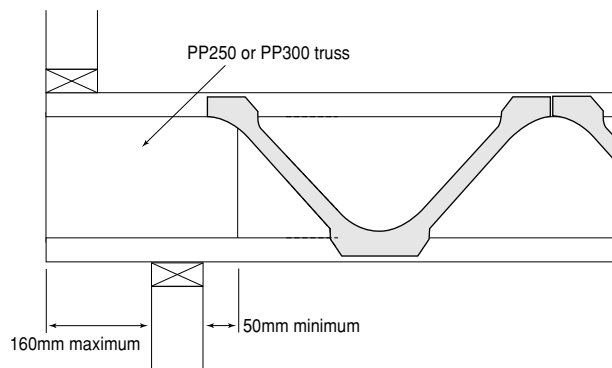

Posi-TRUSS®

Posi-STRUT standard outrigger system is recommended for Posi-TRUSS with small cantilevers with the following limitations.

Endwall supporting max 9m span trusses for:

- Tiled roof @ 600 crs.
- Sheet roof @ 900 crs.
- Not for girder loads
- Max. wall height of 2400mm

For girder loads contact MiTek state engineering office.

SECTION Y-Y

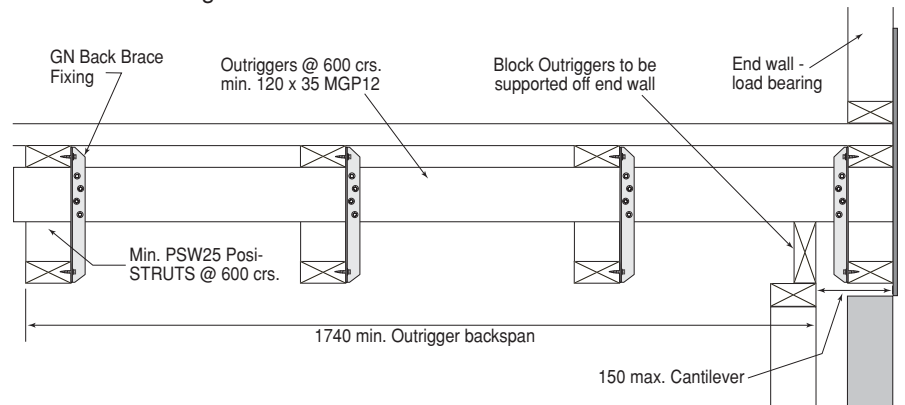

SECTION X-X

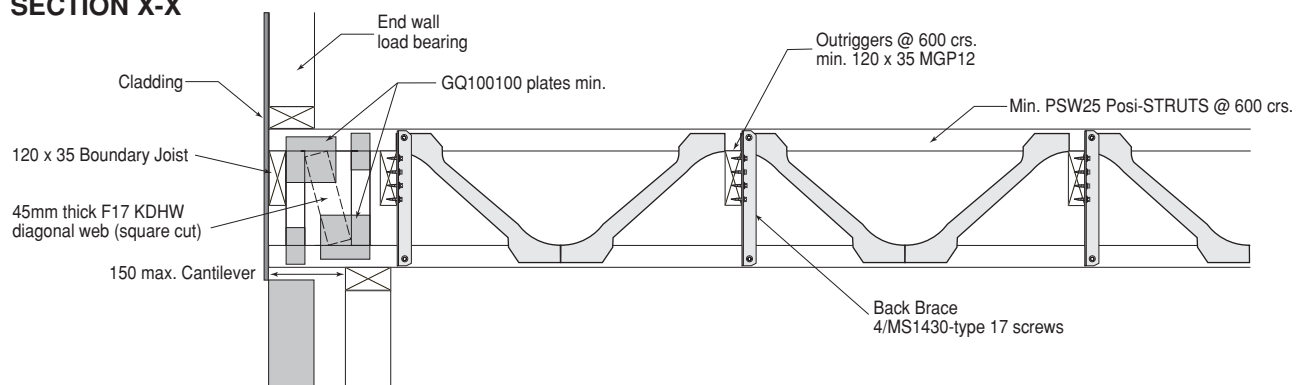

BRACING

End and Internal Support Bracing

Speedbrace bracing at 2400 mm maximum centres along supporting walls.

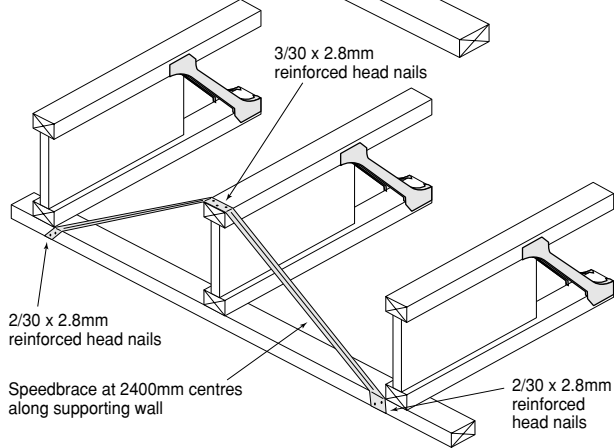
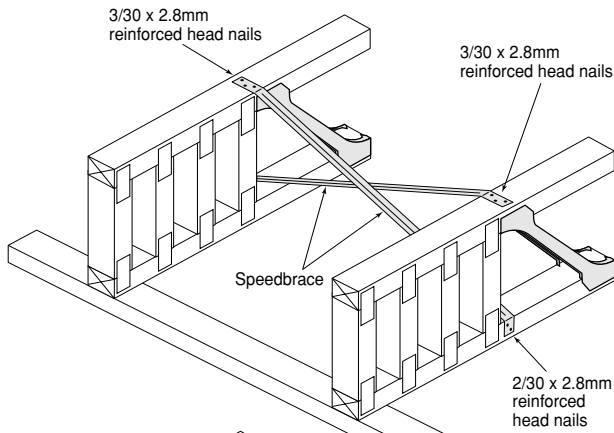
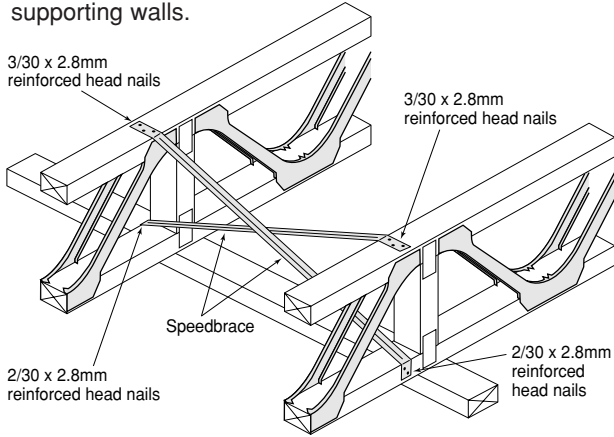

Plywood Panel at 2400 mm maximum centres.

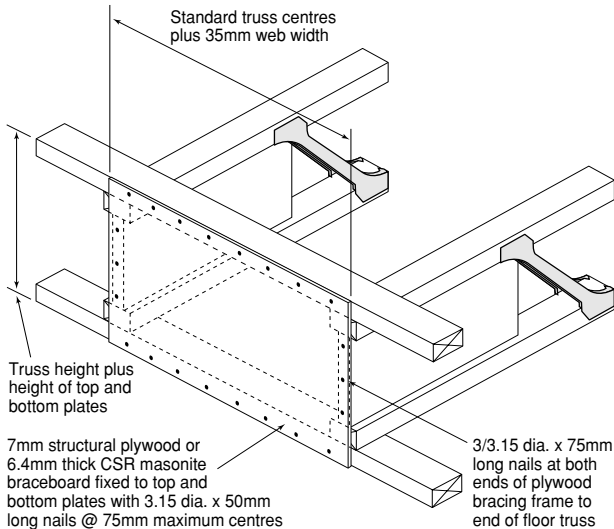

Alternative End and Internal Support Bracing

Plywood Bracing Frame at 2400 mm maximum centres.

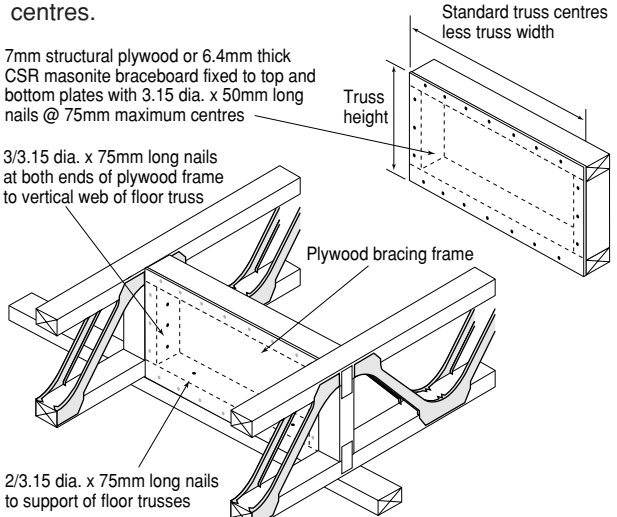

Timber Diagonal Bracing at 1800 mm maximum centres.

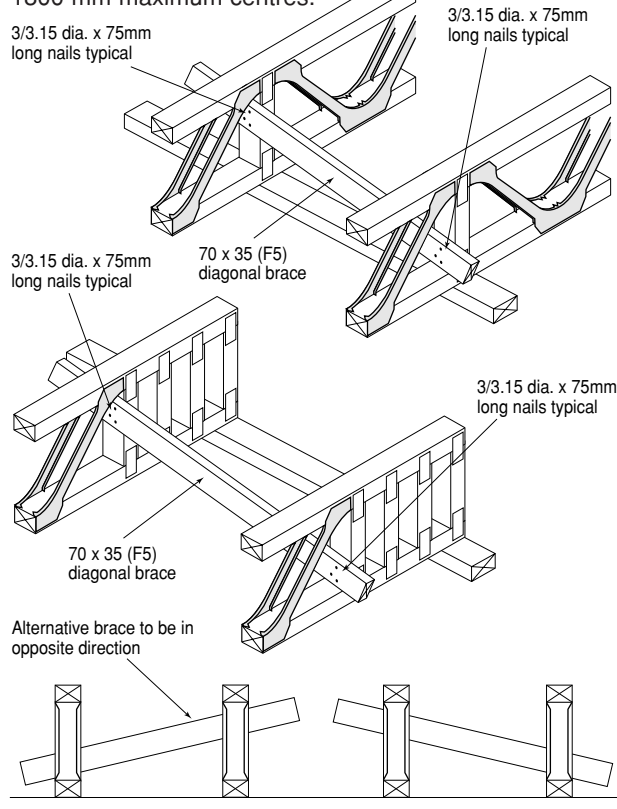

Posi-PLUS® offcut or seasoned timber blocking at 1800 mm maximum centres.

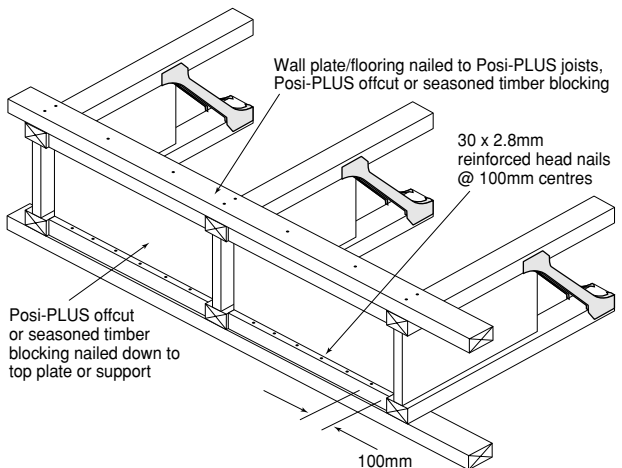

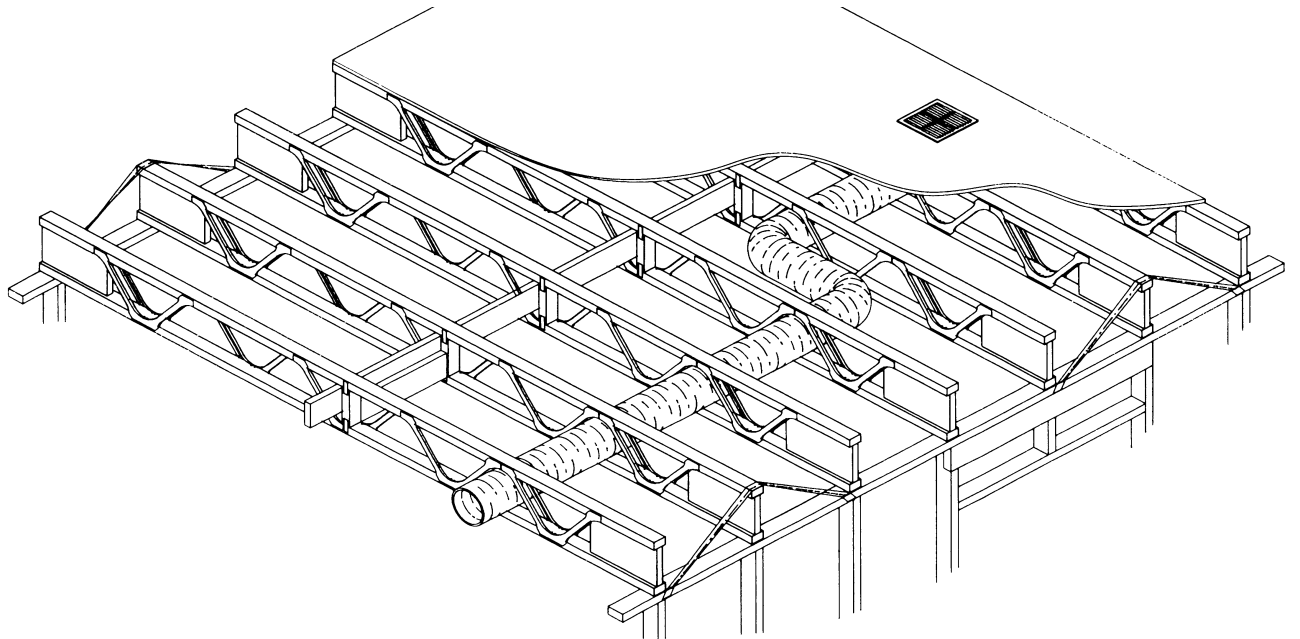
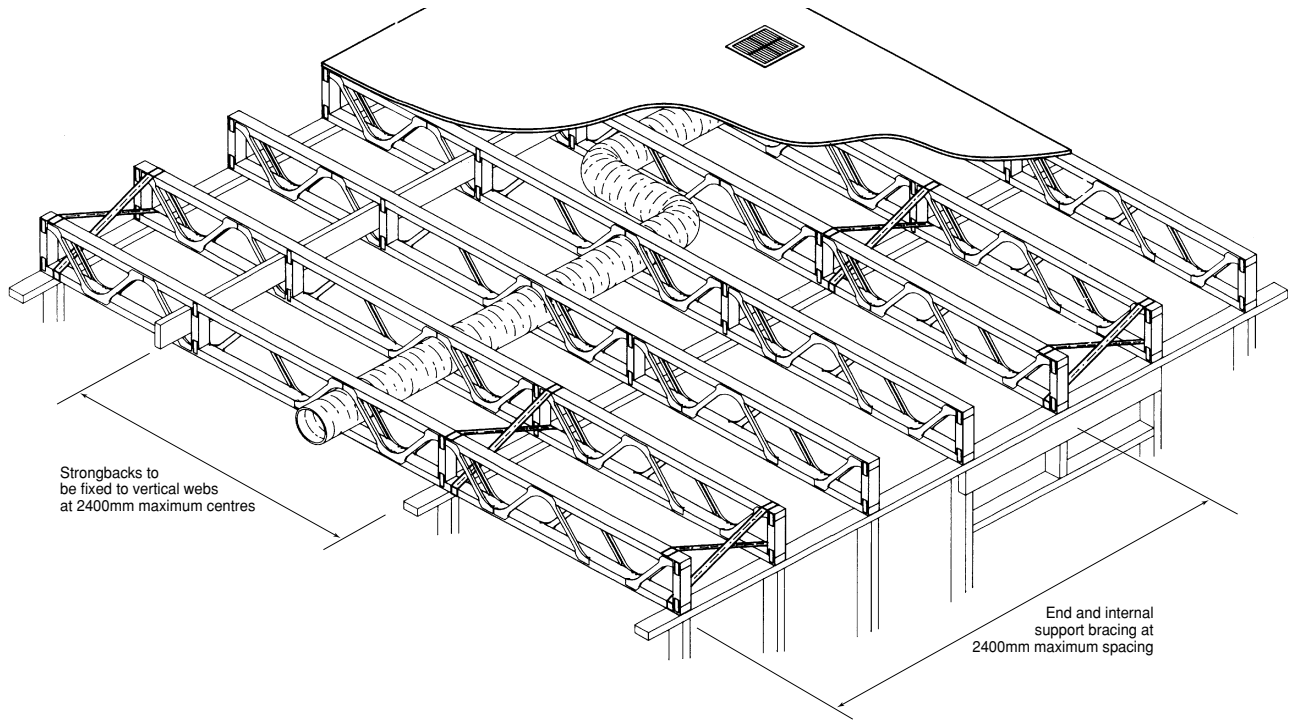

MECHANICAL SERVICES

Posi-STRUT® trusses allow mechanical service ducts and plumbing to be easily accommodated. Maximum clearance available for the different Posi-STRUT® depths is given in Table 14.

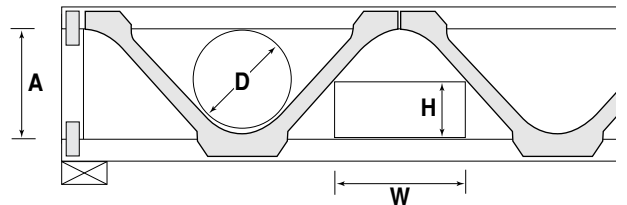

Table 14. Maximum Mechanical Service Clearances

Posi-STRUT® Size	Dimension A	Dimension D	Dimension H						
			50	75	100	125	150	175	200
			Dimension W						
PSW3520	127	120	280	200	120	-	-	-	-
PSW3525	178	170	320	280	230	180	140	-	-
PSW3530	232	220	350	310	280	240	210	170	130
PSW4525	158	150	310	260	200	150	60	-	-
PSW4530	212	200	340	300	260	210	170	130	70
PSW4540	322	280	490	460	410	370	330	300	250

Posi-STRUT® Roof Rafter & Purlin System

INTRODUCTION

Posi-STRUT® rafter and purlin details contained in this manual are only suitable for domestic construction. Although Posi-STRUT® rafters and purlins provide an economical solution for many commercial and light industrial buildings they need to be specifically designed for each building. For structures other than domestic buildings, consult MiTek Australia Ltd. or a licensed Gang-Nail fabricator.

DEFINITION

Posi-STRUT® rafters are trusses placed parallel to roof pitch.

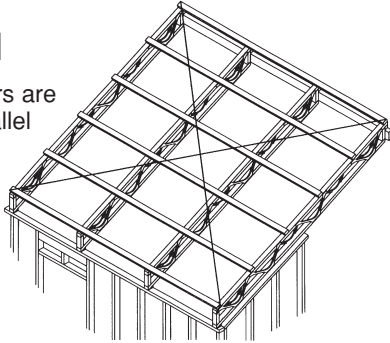

Posi-STRUT® purlins are trusses placed perpendicular to roof pitch.

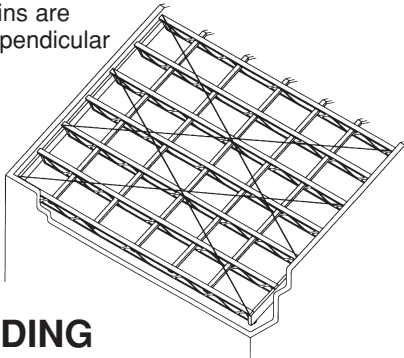

ROOF LOADING

Posi-STRUT® rafters and purlins have been designed to allow for the following dead, live and wind loads.

Dead Loads

Dead loads are due to the weight of the roof structure and permanent fixtures. An allowance has been made for the following permanent loads.

1. Roof and ceiling material

- Terracotta tiles and 13mm plaster battened, maximum load 90kg/m²
- Concrete tiles and 13mm plaster battened, maximum load 80kg/m²
- Steel decking and 13mm plaster battened, maximum load 40kg/m²

2. Self weight of Posi-STRUT® rafters and purlins.

Provision for hot water units and air conditioning units have not been considered, Should there be the need for such services then contact MiTek Australia Ltd. engineers for advice.

Live Loads

Live loads are temporary loads due to maintenance of the roof structure. These loads are in accordance with AS1170.1-1989.

Wind Loads

The Posi-STRUT® rafters and purlins have been designed to conform to AS1170.2-1989 Wind Loading Code, AS4055-1992 Wind Load for Housing for the maximum design gust wind speed in Table 15.

Table 15. Maximum Design Gust Wind Speed

Wind Classification	Max. Design Gust Wind Speed (m/s)		Pressure coefficient	
	Permissible stress method (V_p)	Ultimate Limit State (V_u)	External (C_{pe})	Internal (C_{pi})
N3	41 (W41N)	50	-0.9	0.2
N4	50 (W50N)	61	-0.9	0.2
C1	41 (W41C)	50	-0.9	0.7

CAMBER

Camber of span/300 or 20mm maximum should be set into each truss.

SET OUT

Posi-STRUT® rafters and purlins have been designed for 600, 900, 1200, 1500 and 1800mm centres and in no case should the design maximum truss centres be exceeded.

Sizes for battens or purlins used in conjunction with Posi-STRUT® rafters to be in accordance with AS1684-1999 'Residential Timber-Framed Construction'.

Posi-STRUT® rafters and purlins used in open carports and garages may have higher criteria. In these situations consult MiTek Australia Ltd. engineers for further advice.

SIZES

The Posi-STRUT® rafters and purlins are available in four nominal sizes 200, 250, 300 and 400mm depths.

As all Posi-STRUT® rafters and purlins are made to order, they are produced in the exact length required for the job.

HOLD DOWN DETAILS

Fixing types for various spans, spacing and roof covering are given in Table 16.

For more accurate assessment of hold down requirements on specific projects, refer to MiTek Australia Ltd. engineers.

Details for fixing wall plates to foundations to be by others. The supporting structure must also be designed by others to resist all vertical and horizontal loadings.

Top Chord Support Hold Down Detail

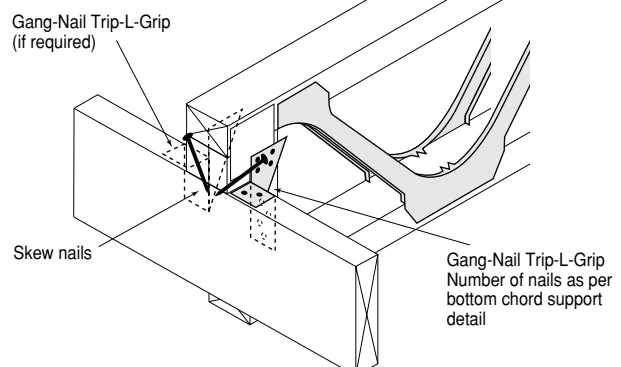

Bottom Chord Support Hold Down Detail

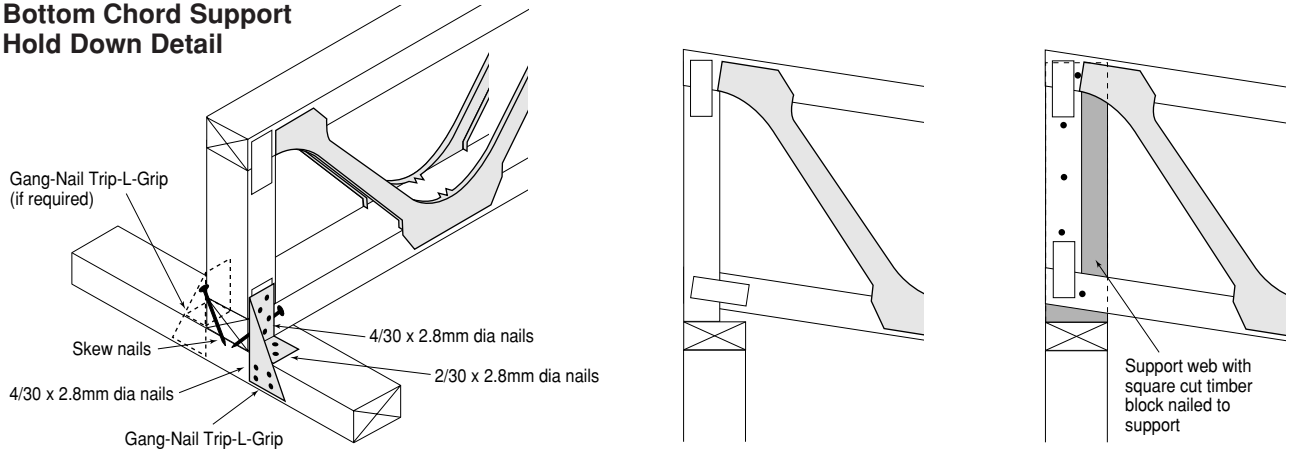
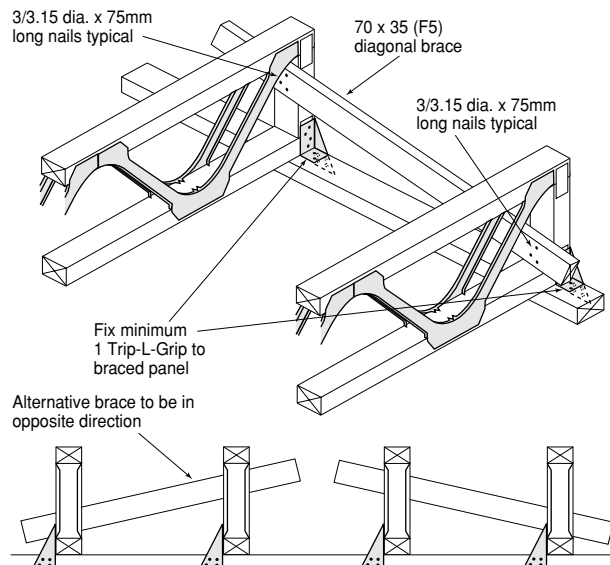

Table 16. Maximum Raked Span (mm)										
Fixing type	Spacing (mm)									
	600		900		1200		1500		1800	
	Joint Group									
	JD4	JD3	JD4	JD3	JD4	JD3	JD4	JD3	JD4	JD3
Concrete tile with ceiling - Wind Classification N4 & C1										
1 Trip-L-Grip	6600	9000	4400	6000	3300	4500	-	-	-	-
2 Trip-L-Grips	13200	18000	8800	12000	6600	9000	-	-	-	-
Terracotta tile with ceiling - Wind Classification N4 & C1										
1 Trip-L-Grip	6900	9400	4600	6200	3400	4700	-	-	-	-
2 Trip-L-Grips	13800	18800	9200	12500	6900	9400	-	-	-	-
Sheet roof with ceiling - Wind Classification N3										
1 Trip-L-Grip	9000	12200	6000	8100	4500	6100	3600	4900	3000	4000
2 Trip-L-Grips	18000	20000	12000	16300	9000	12200	7200	9800	6000	8100
Sheet roof with ceiling - Wind Classification N4										
1 Trip-L-Grip	5600	7600	3700	5000	2800	3800	2200	3000	1800	2500
2 Trip-L-Grips	11200	15200	7400	10100	5600	7600	4500	6100	3700	5000
Sheet roof with ceiling - Wind Classification C1										
1 Trip-L-Grip	5700	7800	3800	5200	2800	3900	2300	3100	1900	2600
2 Trip-L-Grips	11500	15600	7600	10400	5700	7800	4600	6200	3800	5200

END AND INTERNAL SUPPORT BRACING

At external and internal supports, Posi-STRUT® rafters and purlins should be braced back to the top plate with the following:

1. Timber Diagonal Bracing (TDB) at 1200mm centres recommended for PS30 and PS40



2. Plywood Bracing Frame (PBF) at 2400mm centres.

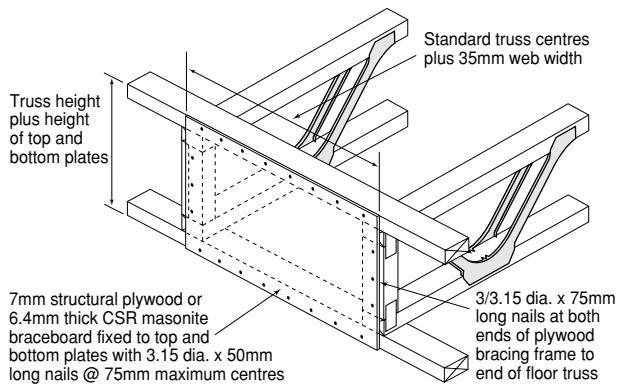

3. Gang-Nail Speedbrace (GSB) at 2400mm centres.

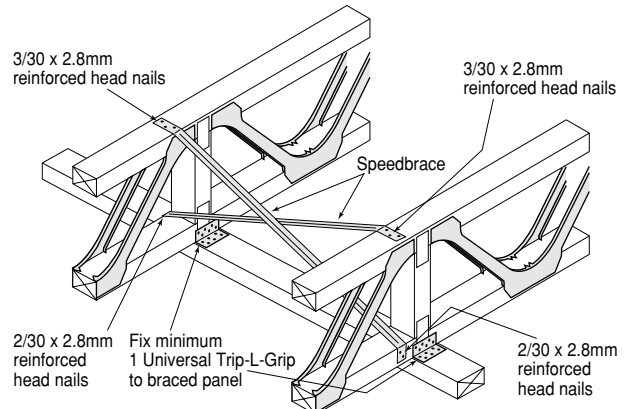

Note:

For top chord supported Posi-STRUT® trusses end panel bracing may be omitted if end web is fastened to end wall at bottom chord level.

HERRINGBONE BRACING

Use of Gang-Nail Bracing Strap to connect the top chord of one Posi-STRUT® to the bottom chord of the adjacent Posi-STRUT®. This type of bracing is to run continuously through the Posi-STRUT® trusses. Refer to detail below.

Herringbone bracing to be at least 3000mm maximum centres. For spans less than 3000mm herringbone bracing is not required.

For PS40 Posi-STRUT® trusses herringbone bracing should be spaced at 1800mm maximum centres.

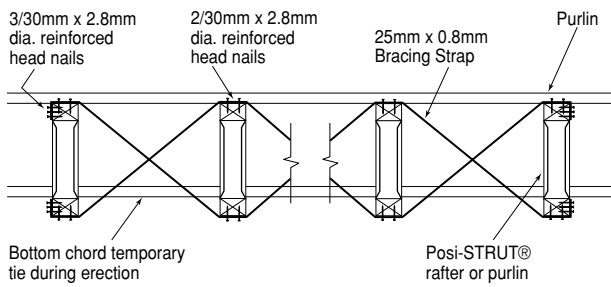

PERMANENT BRACING

These recommendations provide for:

- a) Wind Classification areas N4 and C1.
- b) Walls being stable in their own right.
- c) Roof spans as per Tables 17 to 21.
- d) Maximum truss centres - 1200mm for tiled and 1800mm for sheet roof.

LATERAL RESTRAINT

Top Chord

For roofing battens or roofing purlins use sizes as required by AS1684 National Timber Framing Code, at 900mm maximum centres.

Bottom Chord

For ceiling battens or ceiling joists use sizes as required by AS1684 Residential Timber-Framed Construction at 900mm maximum centres.

For suspended ceilings or where ceiling battens do not provide restraint to bottom chords, eg. metal furring channels clipped to trusses, bottom chord ties may be required. Use 50 x 25 (F5) ties for trusses up to and including 900mm centres, and 70 x 35 (F5) ties for trusses at up to 1800mm centres. Fix ties to each truss with one 3.75mm diameter nail. Splice by lapping over adjacent trusses.

MAXIMUM SPAN CHARTS

Note:

- 1. All charts designed using LSD design method.
- 2. Minimum Joint Group JD5.

Posi-STRUT Size		Posi-STRUT Centres (mm)																			
		600				900				1200				1500				1800			
		Timber Stress Grade																			
		F5	F8	F11	F17	F5	F8	F11	F17	F5	F8	F11	F17	F5	F8	F11	F17	F5	F8	F11	F17
PSW3520	35 x 70	2400	4800	5000	5500	1800	4100	4400	4800	1300	3600	4000	4300	1800	3300	3600	3600	1700	2500	2700	3100
	35 x 90	2600	5200	5500	6000	2600	4500	4800	5200	2500	4100	4300	4400	2400	3600	3600	3600	2400	3100	3100	3100
PSW3525	35 x 70	3000	5500	6000	6600	2500	4900	5200	5700	1900	4500	4700	5200	1900	4000	4400	4800	1900	2900	3300	4000
	35 x 90	3600	6200	6500	7200	4100	5400	5700	6200	3600	4900	5100	5600	3100	4500	4700	5300	2500	4200	4400	4600
PSW3530	35 x 70	3700	6600	7000	7700	3600	5700	6100	6600	3000	5200	5500	6000	2500	4600	5000	5700	1900	3300	3800	4500
	35 x 90	4900	7200	7600	7700	4800	6300	6500	7200	4200	5700	5900	6700	3700	5200	5600	5700	3200	4800	4800	4800
PSW4525	45 x 70	4800	6000	6300	7000	3700	5300	5500	6100	3700	4800	5000	5500	3600	4400	4600	4900	2700	3300	3700	4200
	45 x 90	6000	6600	6900	7600	4900	5700	6000	6600	4700	5200	5400	5900	4400	4800	4900	5000	3900	4200	4200	4200
PSW4530	45 x 70	5100	7100	7400	8100	4900	6200	6400	7100	4300	5600	5900	6400	4100	5200	5300	5300	3100	3900	4300	4500
	45 x 90	6800	7700	8000	8800	6100	6700	7000	7700	5600	6100	6400	6500	5100	5300	5300	5300	4500	4500	4500	4500
PSW4540	45 x 70	6200	9100	9500	10100	6000	7900	8100	9000	4800	7000	7400	7900	4800	6300	6400	6400	3400	4800	5200	5500
	45 x 90	8400	9700	10000	10600	7700	8400	8900	9700	6600	7700	7900	7900	6000	6400	6400	6500	5500	5500	5500	5500
		Timber Stress Grade																			
		MGP10	MGP12	MGP15	MGP10	MGP12	MGP15	MGP10	MGP12	MGP15	MGP10	MGP12	MGP15	MGP10	MGP12	MGP15	MGP10	MGP12	MGP15		
PSW3520	35 x 70	3000	5300	5700	2900	4700	4900	2000	4100	4300	2000	3600	3600	1900	3100	3100					
	35 x 90	4200	5800	6200	3600	5100	5400	3600	4300	4400	3000	3600	3600	2500	3100	3100					
PSW3525	35 x 70	3700	6400	6800	3600	5600	5800	2500	5000	5300	2500	4600	4900	2400	3900	4300					
	35 x 90	4900	6900	7400	4800	6000	6300	4200	5400	5700	3900	5000	5400	3400	4600	4600					
PSW3530	35 x 70	3800	7400	7900	3700	6400	6800	3200	5800	6100	3100	5400	5700	3000	4500	4800					
	35 x 90	5500	8100	8600	5400	6900	7400	4900	6300	6800	4500	5700	5700	4400	4800	4800					
PSW4525	45 x 70	5500	6700	7100	4900	5900	6200	4800	5300	5600	4300	4900	4900	3800	4200	4200					
	45 x 90	6800	7300	7800	5900	6400	6800	5300	5800	6100	4900	4900	5000	4200	4200	4200					
PSW4530	45 x 70	6200	7900	8300	6000	6900	7300	5500	6200	6500	5200	5300	5300	4200	4500	4500					
	45 x 90	7900	8500	9100	6900	7500	7900	6300	6500	6500	5300	5300	5300	4500	4500	4500					
PSW4540	45 x 70	8300	10000	10300	7100	8700	9200	6300	7800	7900	5800	6400	6400	5100	5400	5500					
	45 x 90	9900	10500	10900	8800	9500	10000	7800	7900	7900	6400	6400	6400	5500	5500	5500					

Raked Span = Horizontal Span / Cos Ø Where, Ø = Roof Pitch

Table 18. Posi-STRUT® Rafter & Purlin Maximum Spans

Maximum Raked Span for Domestic Roof Loading
 - Steel Deck Roofing with Ceiling - 40kg/m²
 - Wind Classification Area N4
 - Bottom Chord Supported

Raked Span = Horizontal Span / Cos Ø Where, Ø = Roof Pitch

Posi-STRUT Size	Timber Size (mm x mm)	Posi-STRUT Centres (mm)																			
		600				900				1200				1500				1800			
		Timber Stress Grade																			
		F5	F8	F11	F17	F5	F8	F11	F17	F5	F8	F11	F17	F5	F8	F11	F17	F5	F8	F11	F17
PSW3520	35 x 70	2400	4200	4400	4800	1800	3600	3700	3700	1800	2900	2900	2900	1300	2400	2400	2400	1700	2100	2100	2100
	35 x 90	2900	4500	4800	5200	3000	3700	3700	3700	2500	2900	2900	2900	2400	2400	2400	2400	2100	2100	2100	2100
PSW3525	35 x 70	3000	5000	5300	5700	2500	4300	4500	5000	1900	3900	4100	4300	1900	3300	3500	3500	1900	2700	3000	3000
	35 x 90	3600	5400	5600	6200	3900	4700	4900	5500	3400	4200	4300	4300	2600	3500	3500	3500	2200	3000	3000	3000
PSW3530	35 x 70	3700	5800	6000	6600	3600	5000	5300	5900	3000	4500	4500	4500	2500	3700	3700	3700	1900	2900	3200	3200
	35 x 90	4900	6300	6600	6600	4600	5400	5800	5900	4000	4500	4500	4500	2900	3700	3700	3700	2400	3200	3200	3200
PSW4525	45 x 70	4800	5300	5500	6100	3700	4600	4800	5100	3500	3900	3900	3900	3100	3300	3300	3300	2600	2800	2800	2800
	45 x 90	5200	5700	6000	6600	4600	5000	5100	5100	3900	3900	3900	4000	3300	3300	3300	3300	2800	2800	2800	2800
PSW4530	45 x 70	5100	6200	6500	7100	4700	5400	5400	5500	4100	4200	4200	4200	3300	3500	3500	3500	2800	3000	3000	3000
	45 x 90	6100	6700	7000	7800	5300	5500	5500	5500	4200	4200	4200	4300	3500	3500	3500	3500	3000	3000	3000	3000
PSW4540	45 x 70	6200	7900	8300	8400	5500	6600	6600	6600	4600	5100	5100	5100	4300	4200	4200	4200	2600	3600	3600	3600
	45 x 90	7800	8500	8900	9800	6500	6600	6600	6700	5100	5100	5100	5200	3200	4200	4200	4200	3400	3600	3600	3600
		Timber Stress Grade																			
		MGP10	MGP12	MGP15	MGP10	MGP12	MGP15	MGP10	MGP12	MGP15	MGP10	MGP12	MGP15	MGP10	MGP12	MGP15	MGP10	MGP12	MGP15		
PSW3520	35 x 70	2500	4700	5000	2900	3700	3700	2000	2900	2900	2000	2400	2400	1900	2100	2100					
	35 x 90	3700	5100	5300	3700	3700	3700	2900	2900	2900	2400	2400	2400	2100	2100	2100					
PSW3525	35 x 70	3700	5500	5900	3600	4800	5100	2500	4300	4300	2500	3500	3500	2000	3000	3000					
	35 x 90	4900	6000	6400	4100	5300	5600	4000	4300	4300	3000	3500	3500	2300	3000	3000					
PSW3530	35 x 70	3800	6400	6800	3700	5700	5800	3400	4500	4500	2700	3700	3700	2300	3200	3200					
	35 x 90	5500	7000	7600	5200	5900	5900	4400	4500	4500	3600	3700	3700	2700	3200	3200					
PSW4525	45 x 70	5400	5900	6200	4600	5100	5100	3900	3900	3900	3300	3300	3300	2800	2800	2800					
	45 x 90	5900	6400	6800	5100	5100	5100	3900	3900	4000	3300	3300	3300	2800	2800	2800					
PSW4530	45 x 70	6200	6900	7300	5300	5400	5500	4200	4200	4200	3500	3500	3500	3000	3000	3000					
	45 x 90	6900	7500	8000	5500	5500	5500	4200	4200	4200	3500	3500	3500	3000	3000	3000					
PSW4540	45 x 70	7900	8800	9300	6300	6600	6600	5100	5100	5100	4000	4200	4200	3300	3600	3600					
	45 x 90	8800	9500	9700	6600	6600	6700	5100	5100	5100	4200	4200	4200	3600	3600	3600					

Table 19. Posi-STRUT® Rafter & Purlin Maximum Spans

Maximum Raked Span for Domestic Roof Loading
 - Steel Deck Roofing with Ceiling - 40kg/m²
 - Wind Classification Area C1
 - Bottom Chord Supported

Raked Span = Horizontal Span / Cos Ø Where, Ø = Roof Pitch

Posi-STRUT Size	Timber Size (mm x mm)	Posi-STRUT Centres (mm)																			
		600				900				1200				1500				1800			
		Timber Stress Grade																			
		F5	F8	F11	F17	F5	F8	F11	F17	F5	F8	F11	F17	F5	F8	F11	F17	F5	F8	F11	F17
PSW3520	35 x 70	2400	4200	4400	4900	2400	3700	3800	3800	1300	3000	3000	3000	1300	2500	2500	2500	1300	2100	2100	2100
	35 x 90	2600	4600	4800	5200	3000	3800	3800	3900	2500	3000	3000	3100	2100	2500	2500	2500	2100	2100	2100	2200
PSW3525	35 x 70	3000	5100	5300	5800	2500	4400	4600	5100	1900	4000	4100	4300	1900	3500	3500	3500	1900	2900	3000	3000
	35 x 90	3600	5500	5700	6200	3800	4700	4900	5600	3400	4300	4300	4300	2700	3500	3500	3500	2700	3000	3000	3000
PSW3530	35 x 70	3700	5900	6100	6700	3600	5100	5300	5900	3000	4500	4500	4500	2500	3700	3700	3700	1900	3100	3100	3100
	35 x 90	4900	6300	6600	6700	4600	5600	5900	5900	4000	4500	4500	4500	3000	3700	3700	3700	2900	3100	3100	3100
PSW4525	45 x 70	4800	5300	5600	6100	3700	4700	4900	5300	3700	4200	4200	4200	3200	3400	3400	3400	2700	2900	2900	2900
	45 x 90	5300	5800	6100	6600	4600	5000	5300	5400	4200	4200	4200	4300	3400	3500	3500	3500	2900	2900	2900	3000
PSW4530	45 x 70	5100	6200	6500	7200	4900	5400	5500	5500	4000	4200	4200	4300	3600	3600	3600	3600	3100	3100	3100	3100
	45 x 90	6200	6800	7100	7800	5400	5500	5500	5500	4300	4300	4300	4300	3600	3600	3600	3600	3100	3100	3100	3100
PSW4540	45 x 70	6200	8000	8300	8400	5600	6600	6600	6700	4900	5200	5200	5200	4200	4300	4300	4300	3400	3700	3700	3700
	45 x 90	7900	8500	9000	9900	6600	6600	6700	6700	5200	5200	5200	5200	4300	4300	4300	4400	3700	3700	3700	3800
		Timber Stress Grade																			
		MGP10	MGP12	MGP15	MGP10	MGP12	MGP15	MGP10	MGP12	MGP15	MGP10	MGP12	MGP15	MGP10	MGP12	MGP15	MGP10	MGP12	MGP15		
PSW3520	35 x 70	2500	4700	5000	2900	3800	3800	2000	3000	3000	2000	2500	2500	1300	2100	2100					
	35 x 90	3700	5100	5400	3100	3800	3800	3000	3000	3100	2500	2500	2500	2100	2200	2200					
PSW3525	35 x 70	3700	5700	5900	3600	4800	5300	2500	4300	4300	2600	3500	3500	2000	3000	3000					
	35 x 90	4900	6000	6400	3900	5400	5600	4000	4300	4300	3400	3500	3500	3000	3000	3000					
PSW3530	35 x 70	3800	6500	6900	3700	5800	5900	3300	4500	4500	2700	3700	3700	2700	3100	3100					
	35 x 90	5500	7000	7600	5200	5900	5900	4500	4500	4500	3700	3700	3700	3100	3100	3100					
PSW4525	45 x 70	5500	5900	6300	4700	5200	5400	4100	4200	4200	3400	3400	3400	2900	2900	2900					
	45 x 90	6000	6400	6800	5200	5400	5400	4200	4200	4200	3500	3500	3500	2900	2900	3000					
PSW4530	45 x 70	6200	7000	7400	5400	5500	5500	4200	4200	4200	3600	3600	3600	3100	3100	3100					
	45 x 90	7000	7500	8000	5500	5500	5500	4300	4300	4300	3600	3600	3600	3100	3100	3100					
PSW4540	45 x 70	7900	8700	9300	6500	6600	6600	5200	5200	5200	4300	4300	4300	3700	3700	3700					
	45 x 90	8900	9600	9800	6700	6700	6700	5200	5200	5200	4300	4300	4300	3700	3700	3800					

Table 20. Posi-STRUT® Rafter & Purlin Maximum Spans

Maximum Raked Span for Domestic Roof Loading
 - Concrete Tile Roofing with Ceiling - 80kg/m²
 - Wind Classification Area N3, N4 & C1
 - Bottom Chord Supported

Raked Span = Horizontal Span / Cos Ø Where, Ø = Roof Pitch

Posi-SRUT Size	Timber Size (mm x mm)	Posi-STRUT Centres (mm)											
		600				900				1200			
		Timber Stress Grade											
		F5	F8	F11	F17	F5	F8	F11	F17	F5	F8	F11	F17
PSW3520	35 x 70	1900	3600	4400	4800	1700	3300	3800	4100	1700	3200	3300	3300
	35 x 90	3000	4500	4800	5200	2400	4000	4100	4000	2400	3300	3300	3300
PSW3525	35 x 70	2500	4300	5300	5700	1900	3700	4500	5000	1800	3400	4100	4500
	35 x 90	3600	5400	5600	6200	3100	4600	4900	5400	2500	4100	4400	5000
PSW3530	35 x 70	3100	5000	6200	6600	2500	4500	5300	5800	2400	4000	4800	5200
	35 x 90	4300	6300	6500	6600	3700	5400	5700	6400	3100	4900	5200	5200
PSW4525	45 x 70	3700	5300	5500	6100	3100	4600	4800	5300	3000	4100	4300	4500
	45 x 90	4800	5700	6000	6600	4200	5000	5200	5700	3700	4500	4500	4600
PSW4530	45 x 70	4800	6200	6500	7100	3700	5400	5600	6200	3300	4800	4800	4900
	45 x 90	5500	6700	7000	7700	4900	5800	6100	6400	4500	4900	4900	4900
PSW4540	45 x 70	5300	7700	8100	8600	4600	6600	7100	7700	4100	5800	5900	5900
	45 x 90	6800	8300	8600	9100	5800	7400	7700	7700	5000	5900	5900	5900
		Timber Stress Grade											
		MGP10	MGP12	MGP15	MGP10	MGP12	MGP15	MGP10	MGP12	MGP15	MGP10	MGP12	MGP15
PSW3520	35 x 70	2400	4700	5000	2400	4000	4100	1800	3300	3300			
	35 x 90	3100	5100	5400	3000	4100	4100	3000	3300	3300			
PSW3525	35 x 70	3100	5400	5900	2500	4600	5100	2400	4400	4600			
	35 x 90	4200	6000	6400	3600	5200	5500	3300	4700	5000			
PSW3530	35 x 70	3700	6300	6800	3100	5400	5900	2500	4800	5200			
	35 x 90	5300	7000	7100	4400	6000	6600	3900	5200	5200			
PSW4525	45 x 70	4800	5900	6200	4100	5100	5400	3600	4500	4500			
	45 x 90	5700	6400	6800	4900	5500	5900	4500	4500	4600			
PSW4530	45 x 70	5400	6900	7300	4800	6000	6300	4100	4900	4900			
	45 x 90	6600	7500	7800	5500	6300	6400	4900	4900	4900			
PSW4540	45 x 70	6300	8500	8800	5300	7600	7700	5000	5900	5900			
	45 x 90	8000	8900	9300	7000	7700	7700	5800	5900	5900			

Table 21. Posi-STRUT® Rafter & Purlin Maximum Spans

Maximum Raked Span for Domestic Roof Loading
 - Terracotta Tile Roofing with Ceiling - 90kg/m²
 - Wind Classification Area N3, N4 & C1
 - Bottom Chord Supported

Raked Span = Horizontal Span / Cos Ø Where, Ø = Roof Pitch

Posi-SRUT Size	Timber Size (mm x mm)	Posi-STRUT Centres (mm)											
		600				900				1200			
		Timber Stress Grade											
		F5	F8	F11	F17	F5	F8	F11	F17	F5	F8	F11	F17
PSW3520	35 x 70	1900	4100	4400	4800	1700	3100	3800	3800	1700	2500	3100	3000
	35 x 90	2600	4300	4800	5100	2400	3800	3800	3700	2300	3000	3000	3000
PSW3525	35 x 70	2400	4300	5200	5700	1900	3900	4500	5000	1800	3300	4100	4500
	35 x 90	3600	5300	5600	6200	3000	4600	4900	5400	2500	4000	4400	4700
PSW3530	35 x 70	3000	4900	6000	6600	2500	4500	5300	5800	2400	3900	4800	5100
	35 x 90	4200	6300	6600	6600	3600	5300	5700	6400	3100	4800	5100	5000
PSW4525	45 x 70	3600	5300	5500	6100	3100	4600	4800	5300	2900	4100	4300	4500
	45 x 90	4800	5700	6000	6600	4100	5000	5200	5600	3600	4500	4500	4500
PSW4530	45 x 70	4300	6200	6500	7000	3700	5300	5600	6200	3300	4700	4800	5000
	45 x 90	5400	6700	7000	7500	4800	5800	6100	6200	4200	5000	5000	4900
PSW4540	45 x 70	5300	7500	7900	8400	4500	6600	7100	7600	3800	5800	6100	6200
	45 x 90	6700	8000	8300	8900	5700	7300	7500	8000	5000	6100	6100	6200
		Timber Stress Grade											
		MGP10	MGP12	MGP15	MGP10	MGP12	MGP15	MGP10	MGP12	MGP15	MGP10	MGP12	MGP15
PSW3520	35 x 70	2400	4500	5000	2400	3800	3800	1800	3100	3100			
	35 x 90	3600	5100	5200	2600	3800	3800	2400	3100	3000			
PSW3525	35 x 70	3000	5200	5900	2500	4600	5100	2400	4400	4600			
	35 x 90	4200	6000	6400	3600	5200	5700	3200	4700	4700			
PSW3530	35 x 70	3600	6400	6800	3000	5200	5900	2500	4600	5100			
	35 x 90	4900	7000	7300	4400	6200	6400	3900	5100	5100			
PSW4525	45 x 70	4500	5900	6200	4100	5100	5400	3600	4500	4500			
	45 x 90	5400	6400	6800	4800	5500	5700	4100	4500	4500			
PSW4530	45 x 70	5300	6900	7200	4500	6000	6400	4100	5000	5000			
	45 x 90	6600	7300	7600	5300	6300	6300	4900	5000	5000			
PSW4540	45 x 70	6100	8200	8600	5100	7400	7700	4900	6100	6100			
	45 x 90	7900	8700	9100	6500	7900	8000	5800	6100	6200			

SPEEDBRACE FIXING

ROOF BRACING - Posi-STRUT Rafters - Trusses are placed parallel to roof pitch.

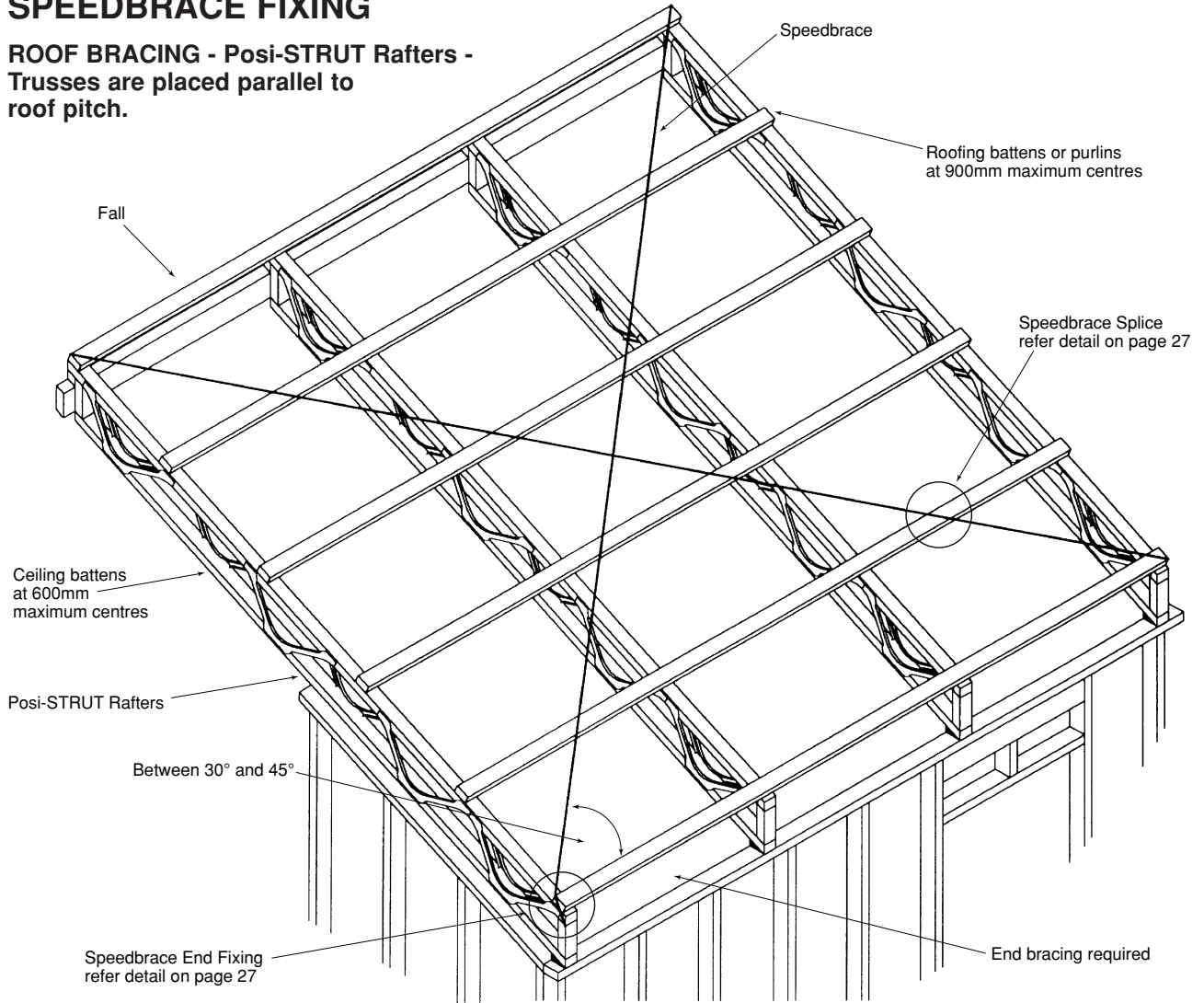

Top Chord Bracing

The top chord bracing shall be arranged according to the following roof lengths using single Speedbrace:

Note:

The following bracing details are designed for the stability of Posi-STRUT® truss only. The stability of supporting and end walls should be checked by others.

a) Roof length 'L' is less than truss span 'S'

Where the roof length 'L' is very short compared to the span 'S' such that it would result in a brace angle greater than 45°, a diagonal bracing arrangement is required as given below. Bracing bays should be spaced across the roof such that the angle is always between 30° and 45°.

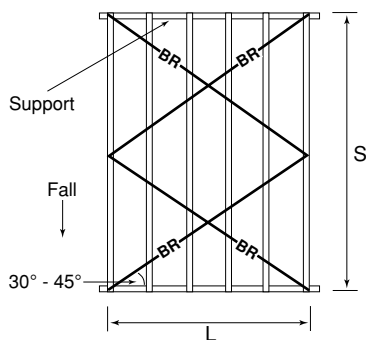

b) Roof length 'L' is 1 to 1.5 times the truss span 'S'

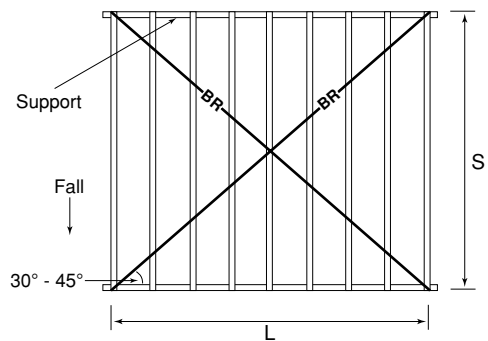

c) Roof length 'L' is long compared to the truss span 'S'

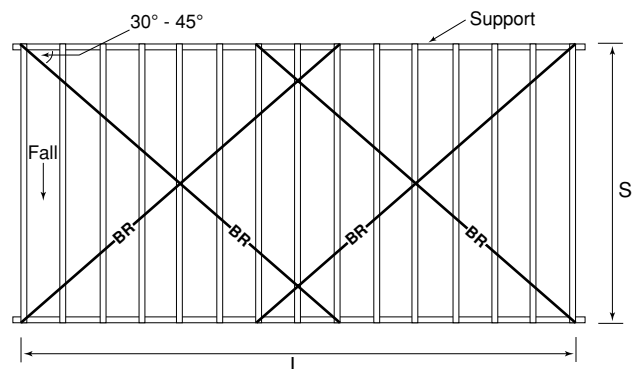

**ROOF BRACING - Posi-STRUT Purlins -
Trusses are placed perpendicular
to roof pitch.**

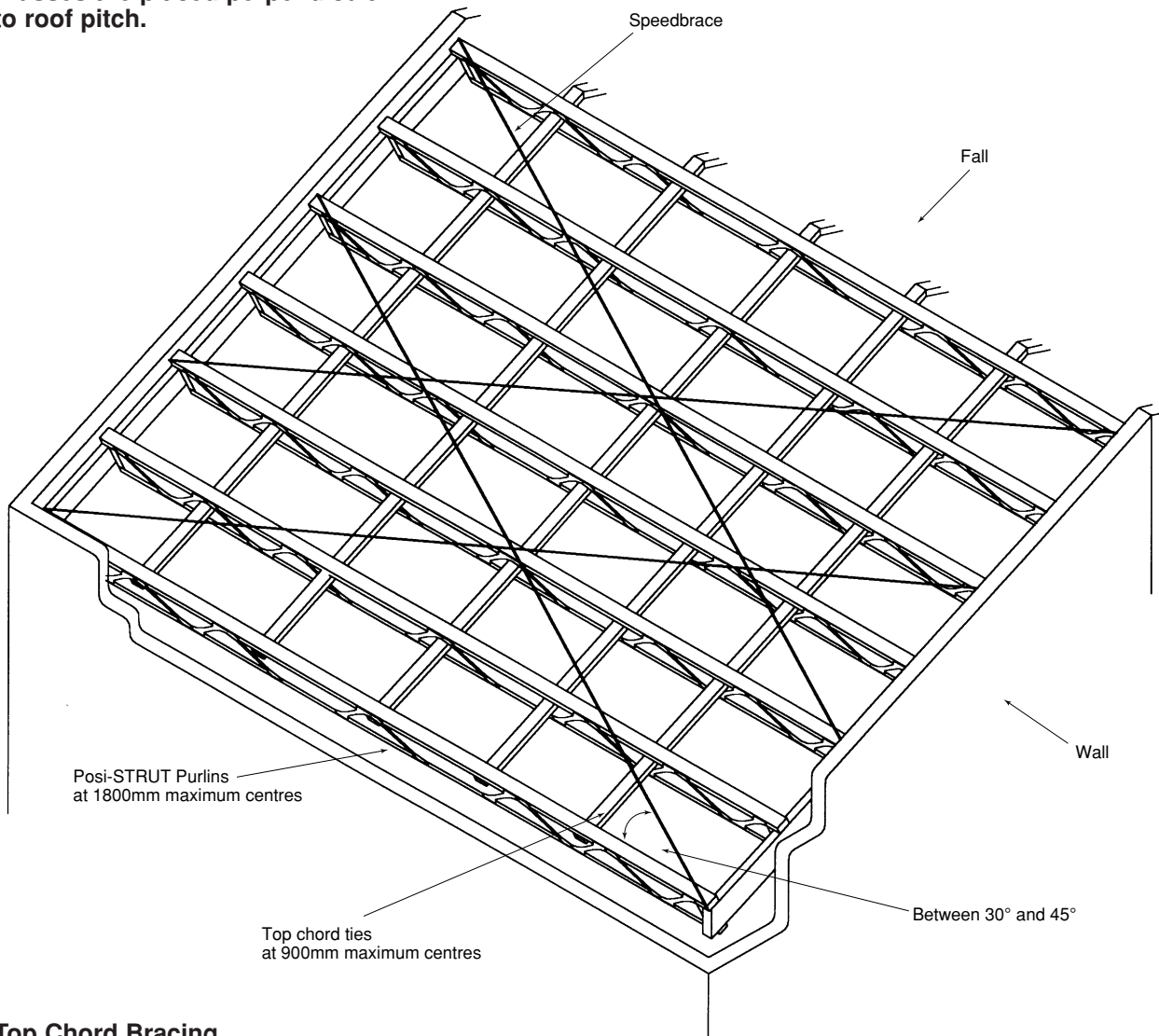

Top Chord Bracing

The top chord bracing shall be arranged according to the following roof lengths using single Speedbrace:

Note:

The following bracing details are designed for the stability of Posi-STRUT® truss only. The stability of supporting and end walls should be checked by others.

a) Roof length 'L' is less than truss span 'S'

Where the roof length 'L' is very short compared to the span 'S' such that it would result in a brace angle greater than 45°, a diagonal bracing arrangement is required as given below. Bracing bays should be spaced across the roof such that the angle is always between 30° and 45°.

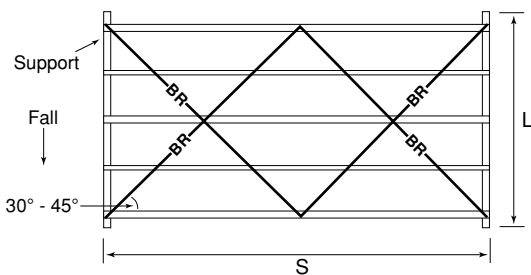

b) Roof length 'L' is 1 to 1.5 times the truss span 'S'

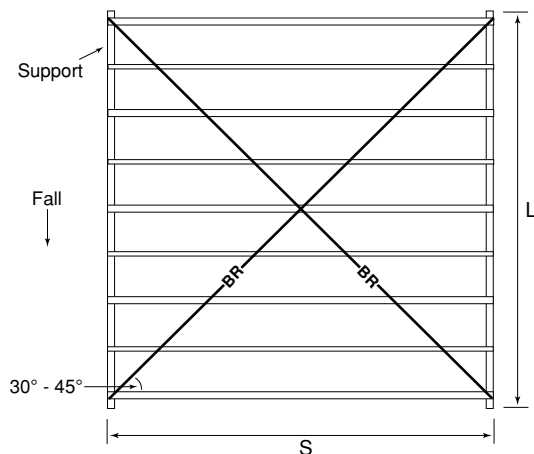

For Posi-STRUT purlins with span greater than 4000mm, double Speedbrace shall be used.

c) Roof length 'L' is long compared to the truss span 'S'

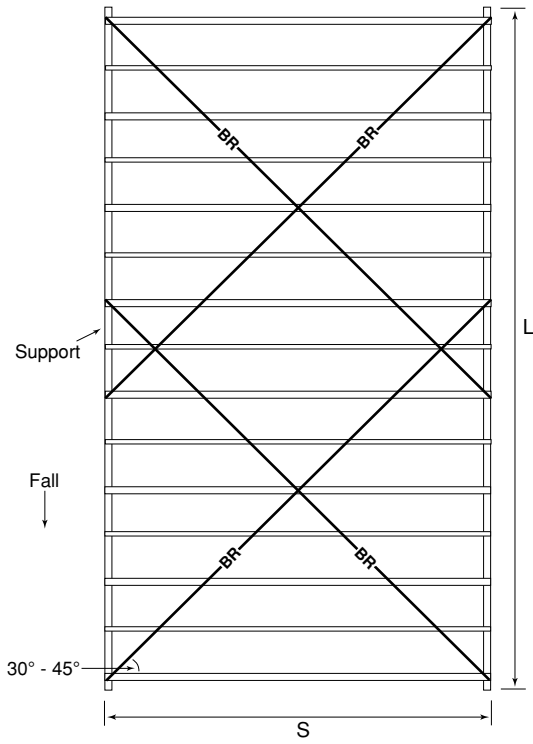

Typical End Fixing Detail

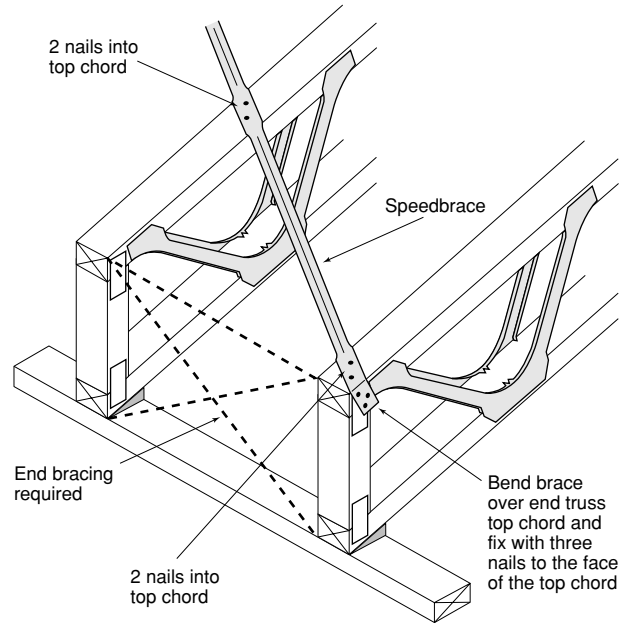

Typical Splice Detail

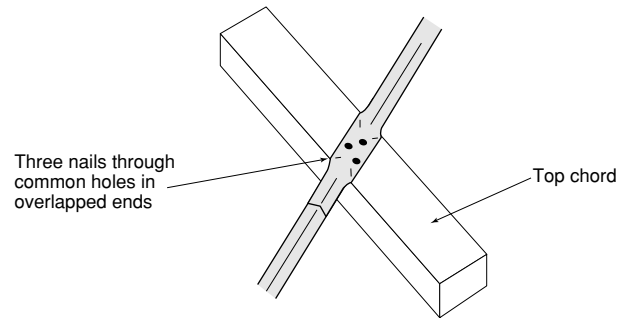



MiTek Australia Ltd. ABN 98 004 564 587

GN007-1/07

Victoria

46 Monash Drive
Lyndhurst 3975
Tel: (03) 8795 8888
Fax: (03) 9702 9464

New South Wales

5/100 Belmore Rd
Riverwood 2210
Tel: (02) 8525 8000
Fax: (02) 8525 8050

Queensland

17 Eagleview Place
Eagle Farm 4009
Tel: (07) 3268 1666
Fax: (07) 3268 2066

South Australia

5/348 Richmond Rd
Netley 5037
Tel: (08) 8234 1326
Fax: (08) 8352 4206

Western Australia

Cnr Karel & Hope Rds
Jandakot 6164
Tel: (08) 9411 2845
Fax: (08) 9411 2848

New Zealand

Tel: (09) 274 7109

Malaysia

Tel: (603) 3176 7473

VISIT OUR WEB SITE: www.mitek.com.au